

Attaching to Diamond Disk:

If the Twin Couler Assembly is used on the Rear of a Diamond Disk the rear shank should be adjusted so coulters run at the same depth as the disk blades or higher.

Warning: *Running the Twin Couler lower than the disk blades will result in damage to the unit that is NOT covered under warranty.*

Rear Shank Holder Bracket

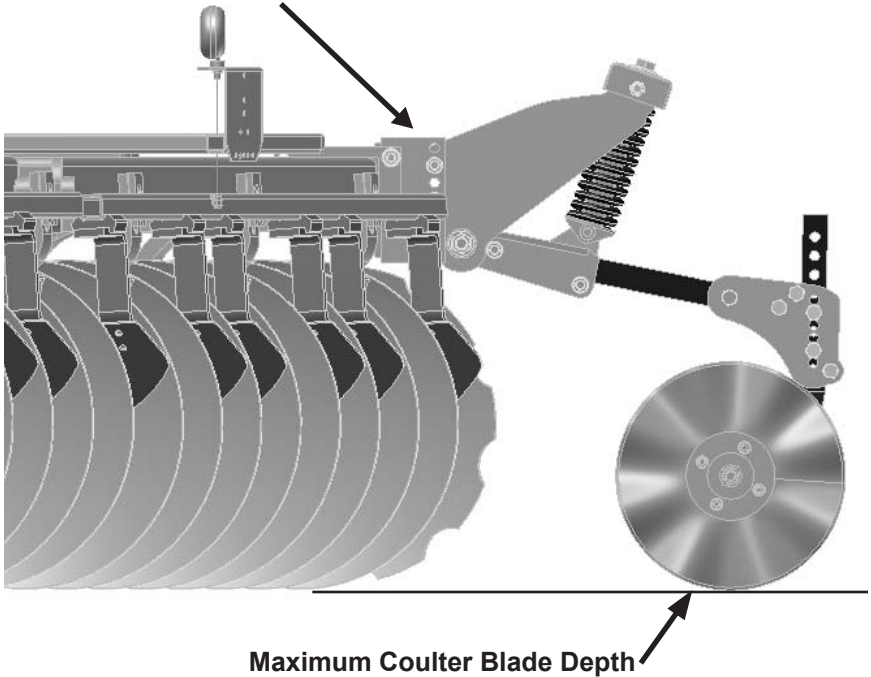

To provide convenient height adjustment, on the rear center of the Diamond Disk, it is recommended to run the Twin Couler on the Summers Two Piece Shank. Components of the Two Piece Shank include:

Qty	PN	Description
1	8T0320	TWO PC. SHANK UPPER DISK
1	8T0322	TWO PC. SHANK LOWER DISK
2	8K6950	ADJ SHANK SIDE PLATE PNTD
6	8X0118A	BOLT 3/4-10NC X 4-1/4" GR5 YZ
6	8X0266	NUT 3/4"-10NC SERFLANG GR2 YZ



SUMMERS
Manufacturing Co., Inc.

8J2000
TWIN COULTER
ATTACHMENT

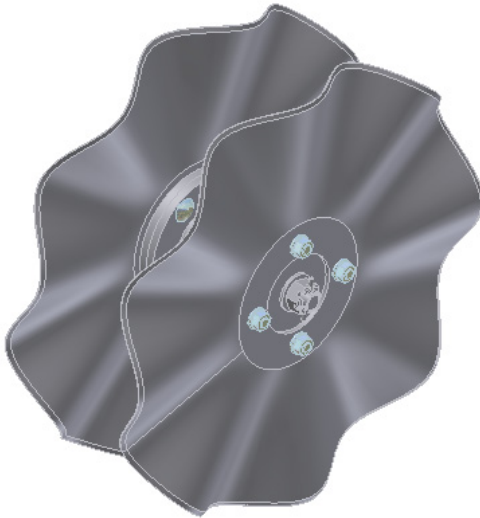

ASSEMBLY, OPERATORS &
PARTS MANUAL

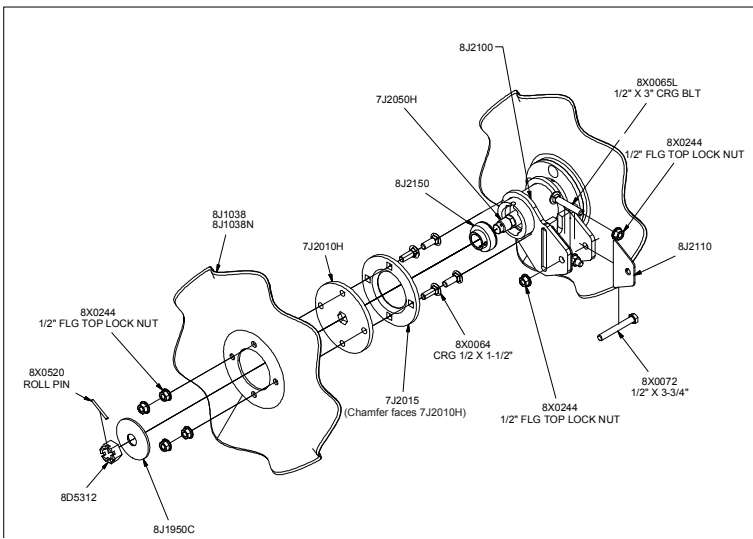

Part Number	Description	Qty.
7J2010H	STL 3/8" X 6 1/4" OD 09-	2
7J2015	STL 3/8 X OD 6-1/4" ID 3-5/16" SQ 07-	2
7J2050H	RND 1-3/16" TWN CLTR SHFT-HEX	1
8D5312	NUT 1"-14TPI HEX SLOT GR2 PLN	2
8J1038	COULTER BLADE 4 BOLT 8 WAVE .197X18"	2
8J1038N	OPT. - NOTCHED COULTER BLADE 4 BOLT 8 WAVE .197X18"	2
8J1950C	WASHER 1.03IDX3-5/8ODX.188 CONV	2
8J2100	TWIN COULTER ATT. WELDMENT	1
8J2110	STL 11GA TWINCLTR SHIM 09-	2
8J2150	BEARING INS P206 REV OUT. RING	2
8X0064	CRG 1/2"-13NC X 1-1/2" GR5 ZDI	8
8X0065L	CRG 1/2-13NC X 3" GR5 ZDI	2
8X0072	BOLT 1/2-13NC X 3-3/4" GR5 YZ	1
8X0244	NUT 1/2"-13NC FLANG TOP LOCK Z	11
8X0520	ROLL PIN 3/16 X 2" ZINC CLEAR	2

Assembly Instructions:

1. Assemble blades to twin coulters hub as shown using 1/2" X 1 1/2" carriage bolts and lock nuts provided. Note: nothing on hub assembly needs to be taken apart, hub plates are designed to be on inside of blade.
2. The bearings are pre-greased and sealed, there is no need for additional grease.
3. Attach Twin Coulters Assembly to shank as shown in following diagrams. Assembly can be mounted in two configurations shown, assembly **CAN NOT** be mounted to rear of shank.
4. Two carriage bolts are provided to attach Twin Coulters Assembly to shank, if length provided is not sufficient, use only Grade 5 longer Carriage bolts.
5. Use Shim (PN 8J2110) provided to fill gap between side of the weldment and shank. Secure with bolt 8X0072 and 8X0244 nut. Tighten bolt 8X0072 so side tab of weldment begins to deform and presses shim against shank. Bolt may deform during this step. If no shim is needed to fill gap, tighten cross bolt so side tabs of weldment touch shank. Additional shims may be ordered if needed for narrow shanks.

High Mount Twin Coulter Attachment

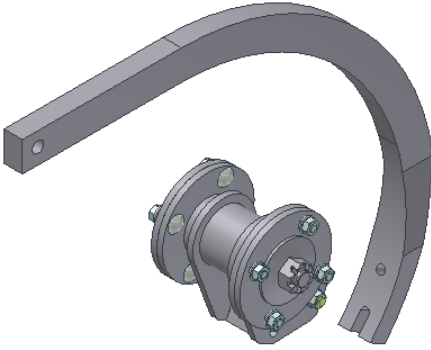

Low Mount Twin Coulter Attachment



Operating Instructions

The twin coulter assembly should be run at field speeds of 6 to 8 mph.

In rocky conditions lower field speeds to avoid damaging blades.

When using the twin coulter on the rear of the disk ensure the blades of twin coulter do not run lower than the blades of the disk

Maintenance

Break in Period

After the first hour of use, stop field operation check all carriage bolts holding the blades for tightness.

Repeat above procedure after first full day of operation.

Check all bolts and fasteners for tightness every 40 hours of operation.

Failure to comply with the above maintenance guidelines may result in voiding the warranty.

Summers Mfg. cannot be responsible for damage due to running 8J2000 with loose fasteners.

**Twin Coulter Assembly always mounts to front of shank.*