

# SUMMERS®

8Z1075 - 3RT TRACK REMOVER

## Operator's Manual



### 3RT 2010 (3RT TRACK REMOVER)



## CAUTION

READ & UNDERSTAND OPERATOR'S MANUAL BEFORE  
OPERATING MACHINE.

*See [www.summersmfg.com](http://www.summersmfg.com) for latest version of all Summers Operator's Manuals.*

**SUMMERS MANUFACTURING CO., INC.**  
**WEB SITE: [www.summersmfg.com](http://www.summersmfg.com)**

DEVILS LAKE, NORTH DAKOTA 58301

(701) 662-5391

8Z1075 - 3RT TRACK REMOVER

## Preface

This manual is intended for use with 3RT 2010 Track Remover for Summers® Manufacturing Company, Inc.

This book is composed of these basic sections: Safety, Operation & Maintenance, Troubleshooting and Parts. The Operation & Maintenance section provides information for the proper operation and maintenance of your Summers Track Remover. A complete Parts breakdown is provided in the Parts section.

Parts are referenced in each drawing. Use this part number when ordering replacement parts from your Summers dealer.

## Disclaimer

It is the policy of this company to improve its products whenever possible and practical to do so. We reserve the right to make changes or improvements in the design or construction of parts at any time without incurring the obligation to install such changes on products previously delivered.

Summers Manufacturing Company, Inc. strongly recommends that each Track Remover operator READ and UNDERSTAND the Operator's Manual before using the machine. In addition, the Operator's Manual should be REVIEWED at least Annually thereafter.

## Contact Information

Summers Manufacturing Company, Inc.  
103 Summers St. NW  
Devils Lake, ND 58301  
Toll Free: 1-800-732-4392  
Local: 1-701-662-5391 (Devils Lake, ND)  
1-605-226-3644 (Aberdeen, SD)  
www.summersmfg.com

*Scan code below for  
the latest version of all  
Summers Operator's Manuals.*



## Owner Registration Information

Bring this information when ordering parts (Serial Number is located attached front of Track Remover).

Name \_\_\_\_\_  
Address \_\_\_\_\_  
City \_\_\_\_\_  
State/Prov. \_\_\_\_\_  
Mail Code \_\_\_\_\_

Size \_\_\_\_\_  
Serial Number \_\_\_\_\_  
(located near front)  
Date Purchased \_\_\_\_\_  
Dealer \_\_\_\_\_

# WARRANTY

---

Summers warrants only products of its manufacture against operational failure caused by defective materials or workmanship which occur during normal use within 36 months from the date by the end user from Summers' dealer.

Summers' obligation is to replace, free of charge, any part of the product that Summers inspection shows to be defective excluding transportation charges to Devils Lake, ND and return and also excluding all transportation costs from Summers' dealer to the dealer's customer and all other costs, such as removal and installation expense.

Summers shall not be liable for loss of time, manufacturing costs, labor, material, loss of profits, consequential damages, direct or indirect, because of defective products whether due to rights arising under the contract of sale or independently thereof, and whether or not such claim is based on contract, tort or warranty.

Written permission for any warranty claim return must be first obtained from authorized Summers' personnel. All returns must be accompanied with a complete written explanation of claimed defects and the circumstances of operational failure.

Written warranty for all component parts used in the manufacture of Summers products is available upon request. Warranty of such component parts will be determined by said component manufacturer upon their inspection of the claimed defective part.

This express warranty is the sole warranty of Summers. There are no warranties, which extend beyond the warranty therein expressly set forth. The sales for products of Summers under any other warranty or guarantee express or implied is not authorized. This warranty voids all previous issues.

**Summers® Manufacturing Co., Inc.**  
Devils Lake, ND 58301

01/16

## Safety Information



This safety alert symbol is used to denote possible danger and care should be taken to prevent bodily injury. When you see this symbol it means ATTENTION, BECOME ALERT! and/or YOUR SAFETY IS INVOLVED!

**WARNING: Safe practices must be followed when working on or operating this equipment. All personnel involved must:**



- Read and understand the instructions and manuals for this machine.
- Be instructed in the safe use of tools and all lifting devices involved in the assembly of this equipment.
- Clear the area of all personnel not involved in the assembly of this machine.

## General Safety Practices

1. READ and UNDERSTAND the Operator's Manual before using any equipment. Review at least annually thereafter.
2. VERIFY all safety devices and shields are in place before using any equipment.
3. KEEP hands, feet, hair and clothing away from moving parts.
4. STOP engine, place all controls in neutral, set parking brake, remove ignition key and wait for all moving parts to stop before servicing, adjusting, maintaining or unplugging.
5. BE CAREFUL when working around high pressure hydraulic system.
6. DO NOT ALLOW RIDERS.

## Safety During Transportation

1. ONLY TOW at a safe speed. Use caution when making corners and meeting traffic.
2. USE safety chain between tractor drawbar and implement hitch when transporting on public roads.
3. ALWAYS use transport locks when transporting on public roads.
4. COMPLY with local lighting, marking and oversize regulations when transporting on highways.
5. FREQUENTLY check for traffic from rear, especially during turns.

---

## Safety Decals



Indicates an immediate hazardous situation that will result in death or serious injury. The color associated with Danger is RED.



Indicates a potentially hazardous situation that could result in death or serious injury. The color associated with Warning is ORANGE.



Indicates a potentially hazardous situation that may result in minor or moderate injury. It may also be used to alert against unsafe practices. The color associated with Caution is YELLOW.



The Notice decals and statements in this manual are to inform the operator of the correct fluids or operational practices for this machine. Failure to follow these notices will result in damage to the machine. The color associated with Notice is GREEN.

1. Keep safety signs clean and legible at all times.
2. Replace safety signs that are missing or have become illegible.
3. Replaced parts that displayed a safety sign should also display the current sign.
4. Safety signs are available from your dealer's parts department or the factory.

### *How to install safety signs?*

1. Be sure that the installation area is clean and dry.
2. Be sure the temperature is above 50° F (10° C).
3. Decide on the exact position before removing the backing paper.
4. Remove the smallest portion of the split backing paper.
5. Align the sign over the specified area and carefully press the small portion with the exposed sticky backing in place.
6. Slowly peel back the remaining paper and carefully smooth the remaining portion of the sign in place.
7. Small air pockets can be pierced with a pin and smoothed out using the piece of sign backing paper.

---

## General Maintenance Safety Practices

**NOTE: Read the entire section before beginning work.**

### *Before You Begin*

- **YOU ARE RESPONSIBLE** for the safe maintenance of the Track Remover.
- **DO NOT ALLOW CHILDREN** or other unauthorized persons within the Track Remover operational area.
- **WEAR PERSONAL PROTECTIVE EQUIPMENT** which could include a hard hat, eye protection, rubber gloves and steel toed boots with slip resistant soles.
- **DO NOT MODIFY** the equipment or substitute parts in any way. Unauthorized modifications may impair the function and/or safety of the machine.
- **USE SUITABLE LIFTING DEVICE** for components which could cause personal injury.
- **BLOCK UP ANY RAISED PART** of the machine. Be sure machine is stable after blocking.
- **ALWAYS INSPECT LIFTING CHAINS AND SLINGS** for damage or wear.
- **BE SURE LIFTING DEVICE IS RATED TO HANDLE THE WEIGHT.**
- **STOP ENGINE**, place all controls in neutral, set parking brake, remove ignition key and wait for all moving parts to stop before servicing or adjusting. For plumbing repairs make sure valves are closed to avoid water or chemical spills.
- **BE SURE PRESSURE IS RELIEVED** from hydraulic circuits before servicing or disconnecting from tractor.
- **USE EXTREME CARE** when assembling, servicing or adjusting.

**Operation Safety**

1. READ AND UNDERSTAND Operator's Manual before using machine. Review at least annually thereafter.
2. VERIFY that all safety devices and shields are in place before using machine.
3. KEEP hands, feet, hair and clothing away from moving parts.
4. STOP engine, place all controls in neutral, set parking brake, remove ignition key and wait for all moving parts to stop before servicing, adjusting, maintaining or unplugging.
5. BE CAREFUL when working around high pressure hydraulic system and farm chemicals.
6. ALWAYS make sure that pressure is relieved from hydraulic circuits before servicing or disconnecting from tractor.
7. DO NOT ALLOW RIDERS.
8. USE EXTREME CARE when making adjustments.
9. KEEP CHILDREN AWAY from machinery at all times.
10. NEVER ALLOW anyone to walk or work under a raised piece of equipment without installing cylinder and transport locks.

**Steps Prior to Operation**

1. COMPLETE WARRANTY REGISTRATION CARD
  - A. Complete and return WARRANTY REGISTRATION CARD located at the beginning of this manual. **RETURNING CARD ENTITLES YOU TO A FREE GIFT.**
  - B. Complete the OWNER REGISTER also located at the beginning of this manual (Serial Number is located on base piece). OWNER REGISTER INFORMATION MAY BE NEEDED WHEN ORDERING PARTS.

---

## Operation

**Note:** This implement is designed for use with Category III or IV 3-Point hitches ONLY. Adapter sleeves are provided when attaching to a Category IV hitch.

## Leveling

1. With implement securely attached to 3-Point hitch, and parked on flat, level ground, lower the implement until it is resting on the ground.
2. Recommended initial setting is level front-to-rear. If rear is higher, lengthen top-link. If front is higher, shorten top-link.
3. Once in the field, if more soil movement is desired, shorten the top-link in increments of  $\frac{1}{4}$ . For additional soil movement see Pages 20 & 21 for changing blade aggressiveness.



## Maintenance Safety

1. STOP engine, place all controls in neutral, set parking brake, remove ignition key and wait for all moving parts to stop before servicing, adjusting or maintaining.
2. BE CAREFUL when working around high pressure hydraulic system.
3. ALWAYS make sure that pressure is relieved from hydraulic circuits before servicing or disconnecting from tractor.
4. USE EXTREME CARE when making adjustments.
5. KEEP CHILDREN AWAY from machinery at all times.
6. NEVER ALLOW anyone to walk or work under a raised piece of equipment without installing cylinder and transport locks.

## PROPER BOLT USE

DO NOT use these values if a different torque value or tightening procedure is given for a specific application. Torque values listed are for general use only. Check tightness of fasteners periodically.

BOLT SIZE	WRENCH SIZE	GRADE 5		GRADE 8	
		ft-lbs	N • m	ft-lbs	N • m
1/4"	7/16" or 3/8"	7	9.5	12	17
5/16"	1/2"	15	20	25	34
3/8"	9/16"	30	41	45	61
7/16"	5/8" or 11/16"	45	61	70	95
1/2"	3/4"	70	95	105	142
9/16" wheel bolts	7/8"	170	231		
5/8"	15/16"	170	231	210	285
5/8" wheel nuts	1-1/16"	240	325		
3/4"	1-1/16"* or 1-1/8"	250	339	375	509
7/8"	1-5/16"	350	475	600	814
1"	1-1/2"	450	610	880	1193
1-1/4"	1-7/8"	500	678		
1-1/2"	2-1/4"	570	773		
2"	3-1/8"	1200	1627		

\*Nylon Lock Nut

3/8/12 TILLAGE

## Maintenance after the 1st day and week of Operation

1. Check for any lose or missing fasteners.
2. Check valves operation and conditions.

## Periodic Maintenance

1. Check tightness of all hardware. Pay special attention to hinges and support bolts.
2. Check Track Remover for damaged or worn parts. Replace as needed.

## Storage

1. Clean and remove all excessive dirt and grease from Track Remover.
2. To prevent rusting, repaint any areas that have been worn, chipped or scratched.



SAE  
GRADE 5



SAE  
GRADE 8

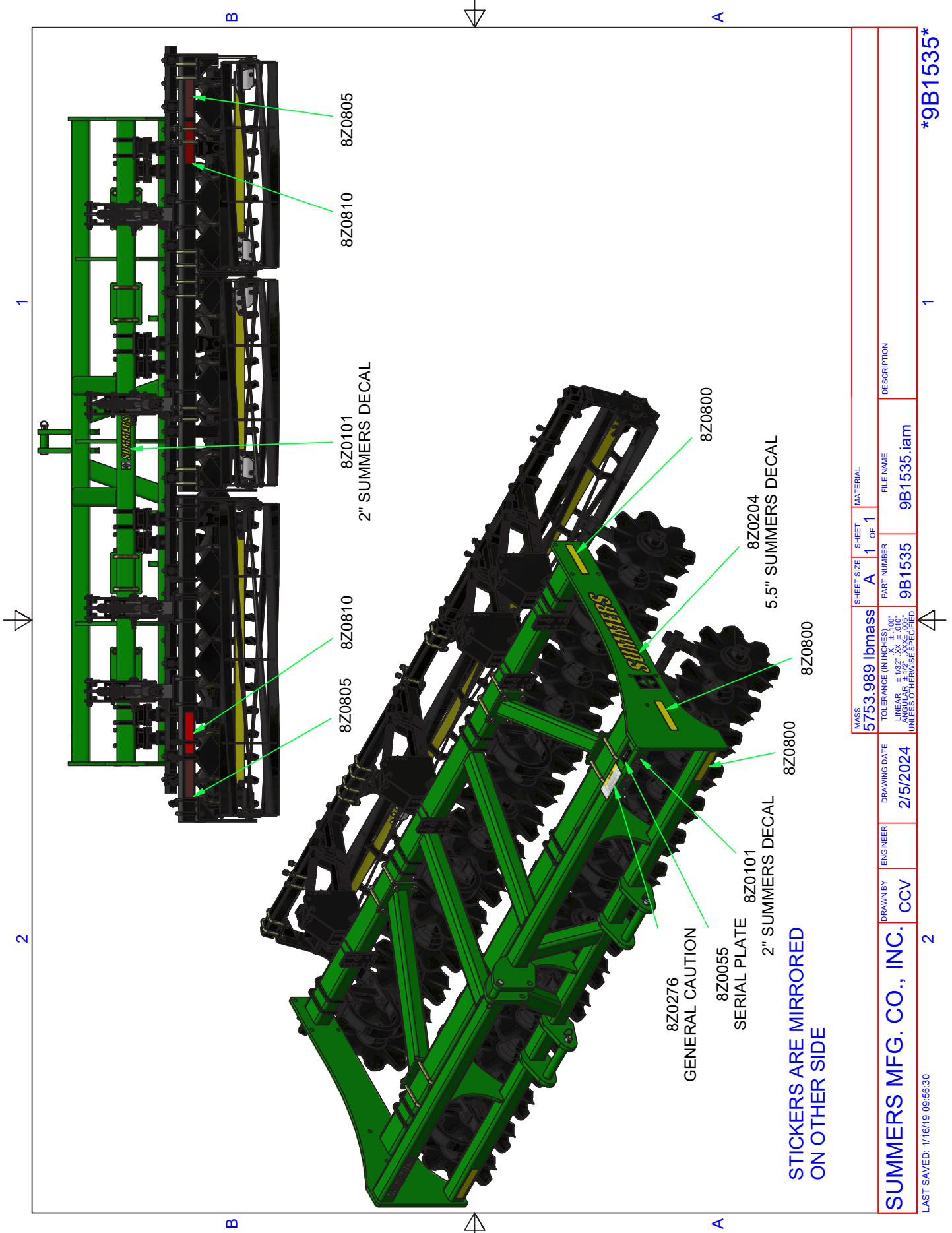

MASS	5753.989 lbmass	SHEET	A	1	OF	1	MATERIAL	
TOLERANCE (IN INCHES)	LINEAR $\pm .127$ ANGULAR $\pm .127$	DRAWING DATE	2/5/2024	PART NUMBER	9B1535	FILE NAME	9B1535.lam	DESCRIPTION
DRAWN BY			ENGINEER	DRAWING DATE		PART NUMBER		
CCV				2/5/2024		9B1535		
SUMMERS MFG. CO., INC.			DRAWN BY			FILE NAME		
LAST SAVED: 1/16/19 09:56:30			ENGINEER			9B1535.lam		
2			2			1		
						*9B1535*		

**90" C-C LAYOUT**

**SEE PAGES 20 & 21 FOR  
ADJUSTMENT ANGLES**

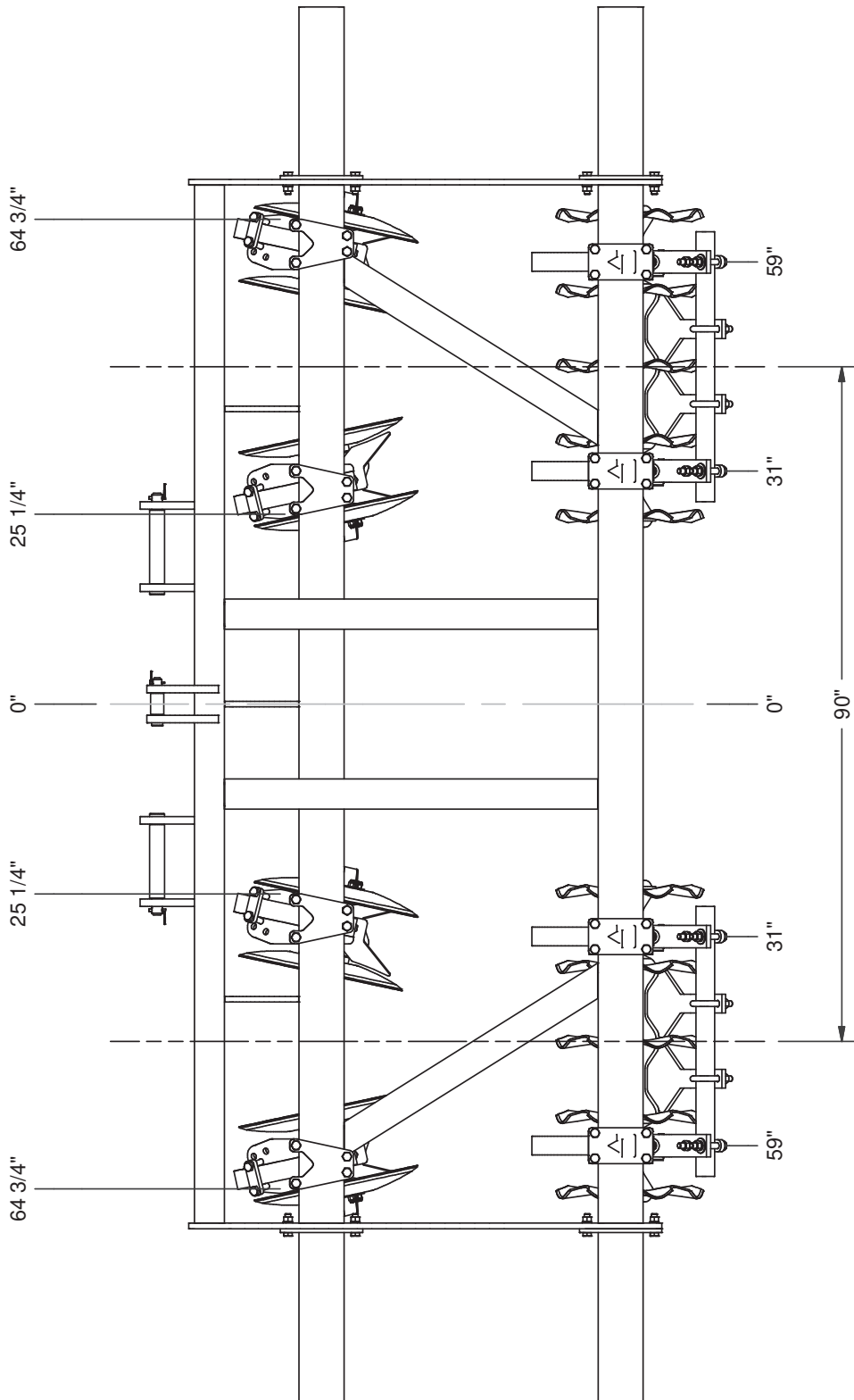

10/13/2016

9B1508.iam/3 PT TRACK REMOVER

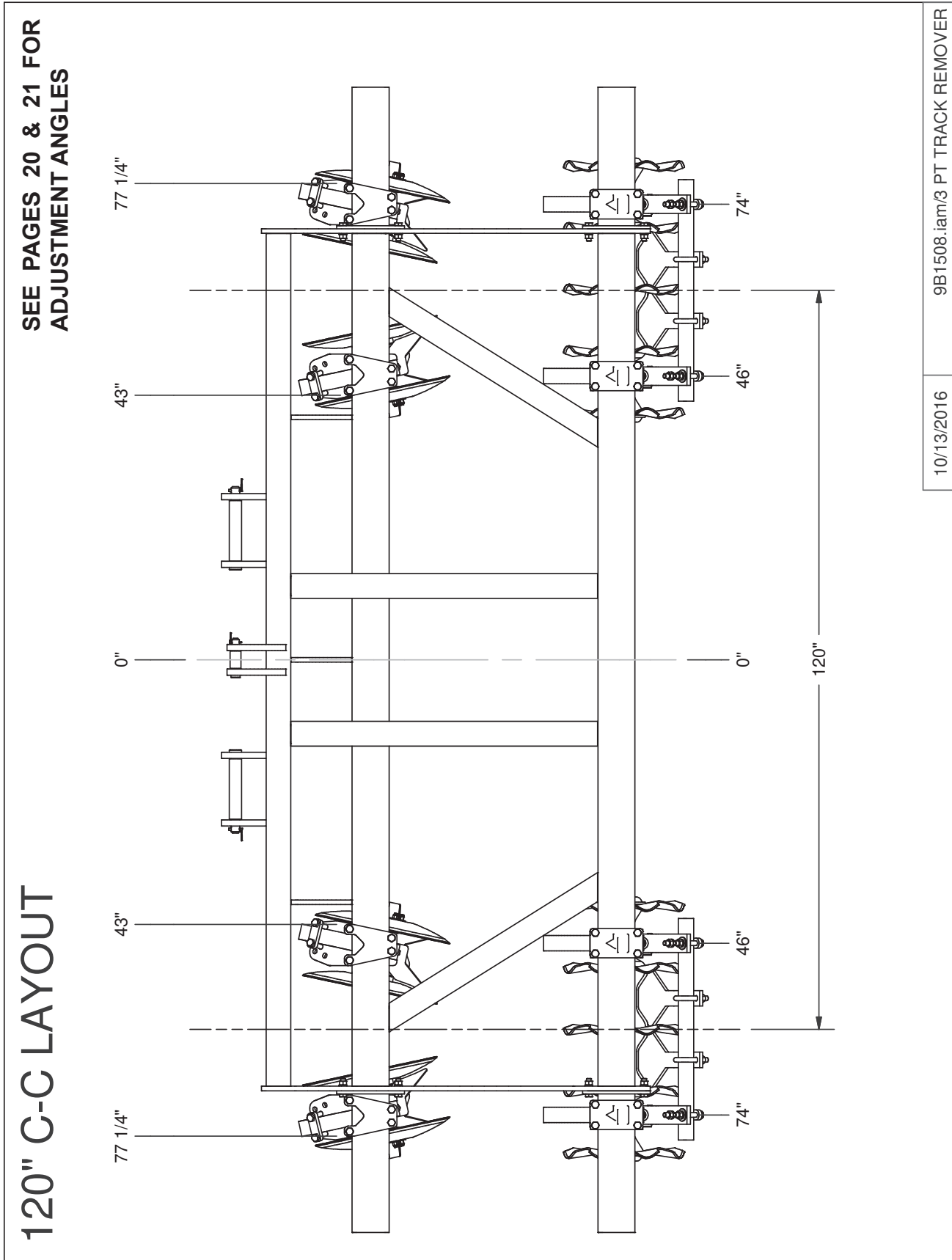

**132" C-C LAYOUT**

SEE PAGES 20 & 21 FOR  
ADJUSTMENT ANGLES

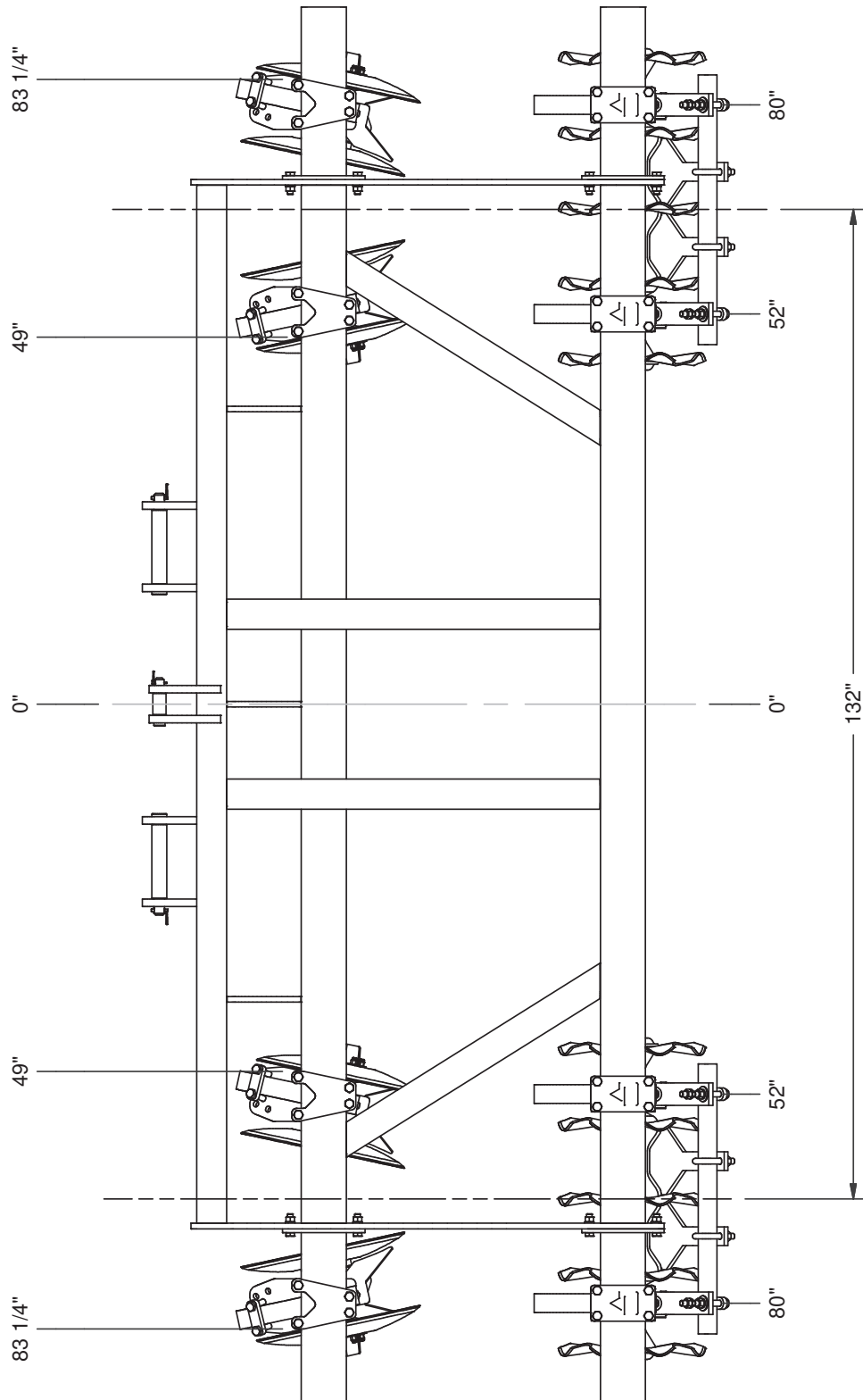

10/13/2016

9B1508.i.am/3 PT TRACK REMOVER

SEE PAGES 20 & 21 FOR  
ADJUSTMENT ANGLES

# 90" C-C LAYOUT TRACK REMOVER PLUS

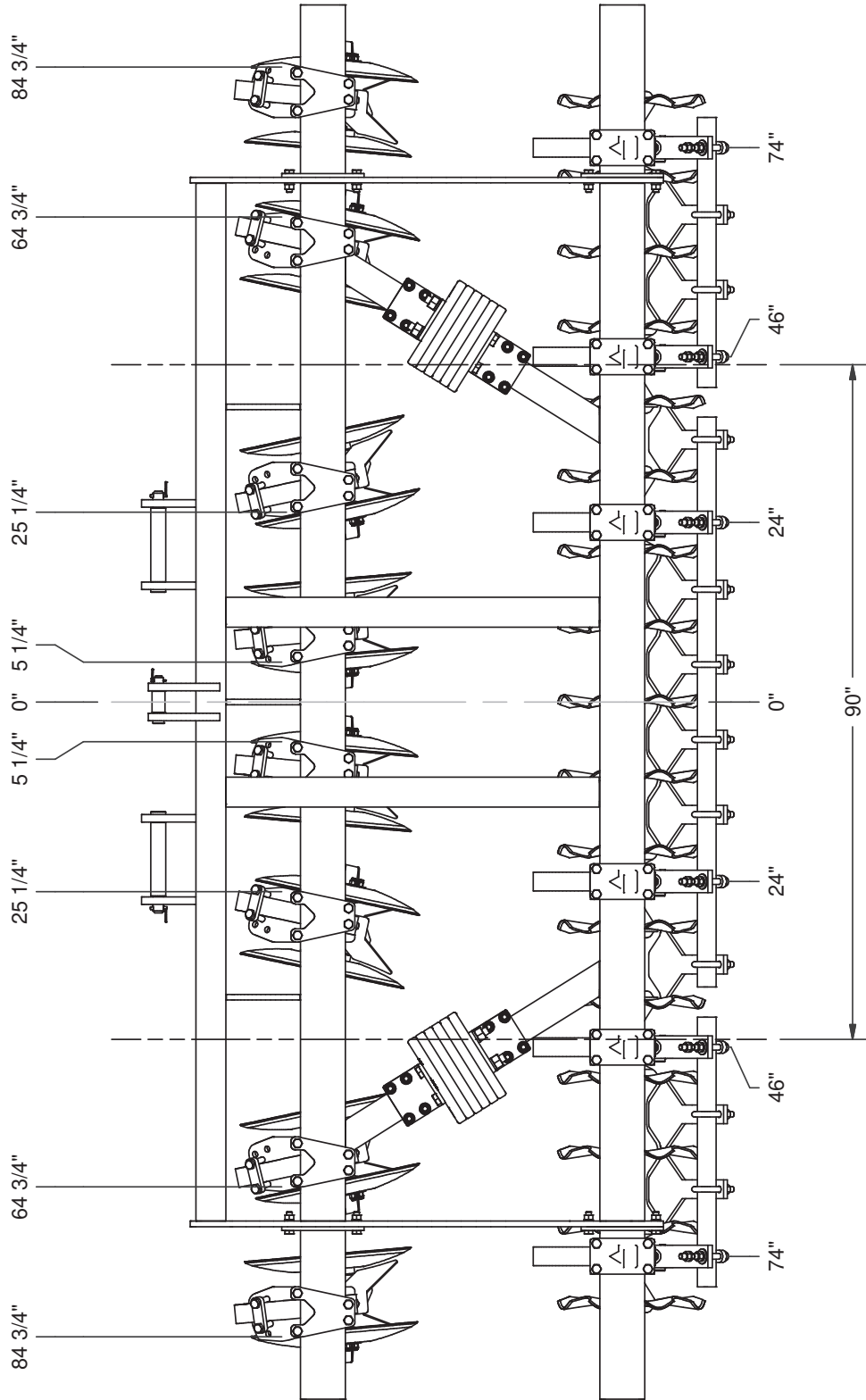

NOTE:  
WHEN CONVERTING FROM A STANDARD TRACK  
REMOVER, SOME PART LOCATIONS WILL CHANGE

10/13/2016 9B1508.iam/3 PT TRACK REMOVER

SEE PAGES 20 & 21 FOR  
ADJUSTMENT ANGLES

**120" C-C LAYOUT  
TRACK REMOVER PLUS**

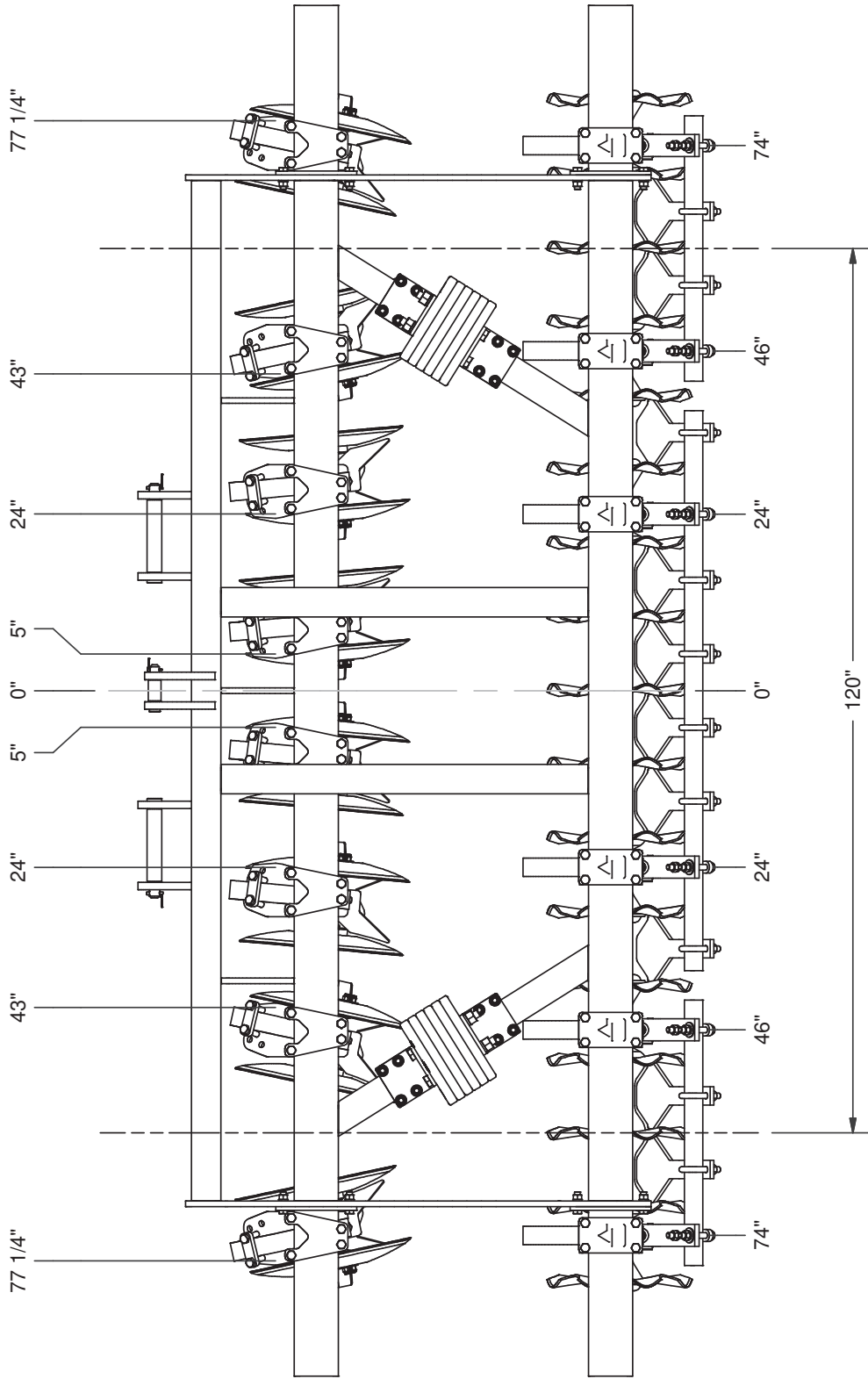

NOTE:  
WHEN CONVERTING FROM A STANDARD TRACK  
REMOVER, SOME PART LOCATIONS WILL CHANGE

10/13/2016

9B1508.iam/3 PT TRACK REMOVER

# 132" C-C LAYOUT TRACK REMOVER PLUS

SEE PAGES 20 & 21 FOR  
ADJUSTMENT ANGLES

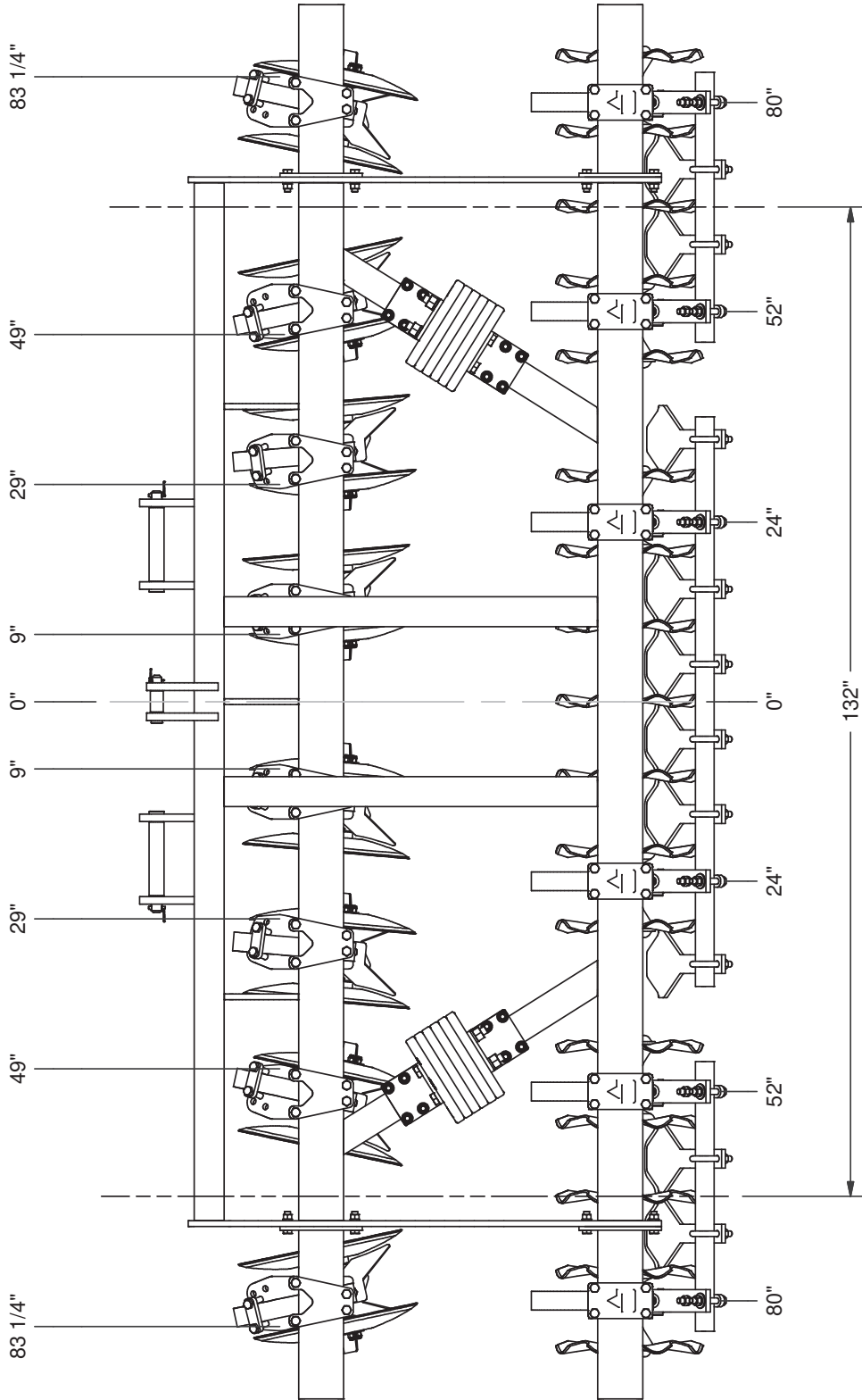

NOTE:  
WHEN CONVERTING FROM A STANDARD TRACK  
REMOVER, SOME PART LOCATIONS WILL CHANGE

10/13/2016

9B1508.iam/3 PT TRACK REMOVER



SEE PAGES 20 & 21 FOR  
ADJUSTMENT ANGLES

**150" C-C LAYOUT**

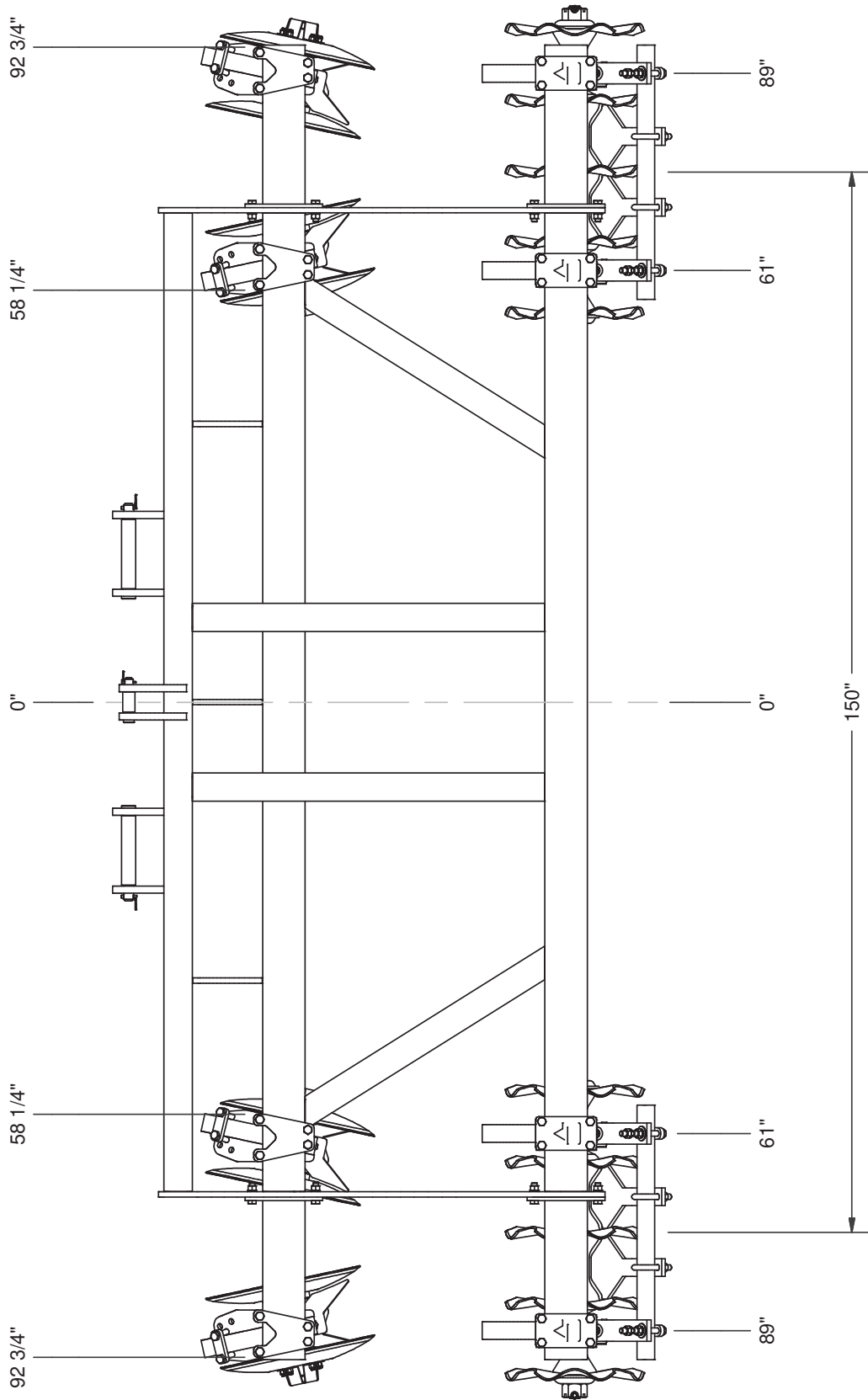

9B1508.i.am/3 PT TRACK REMOVER

10/13/2016

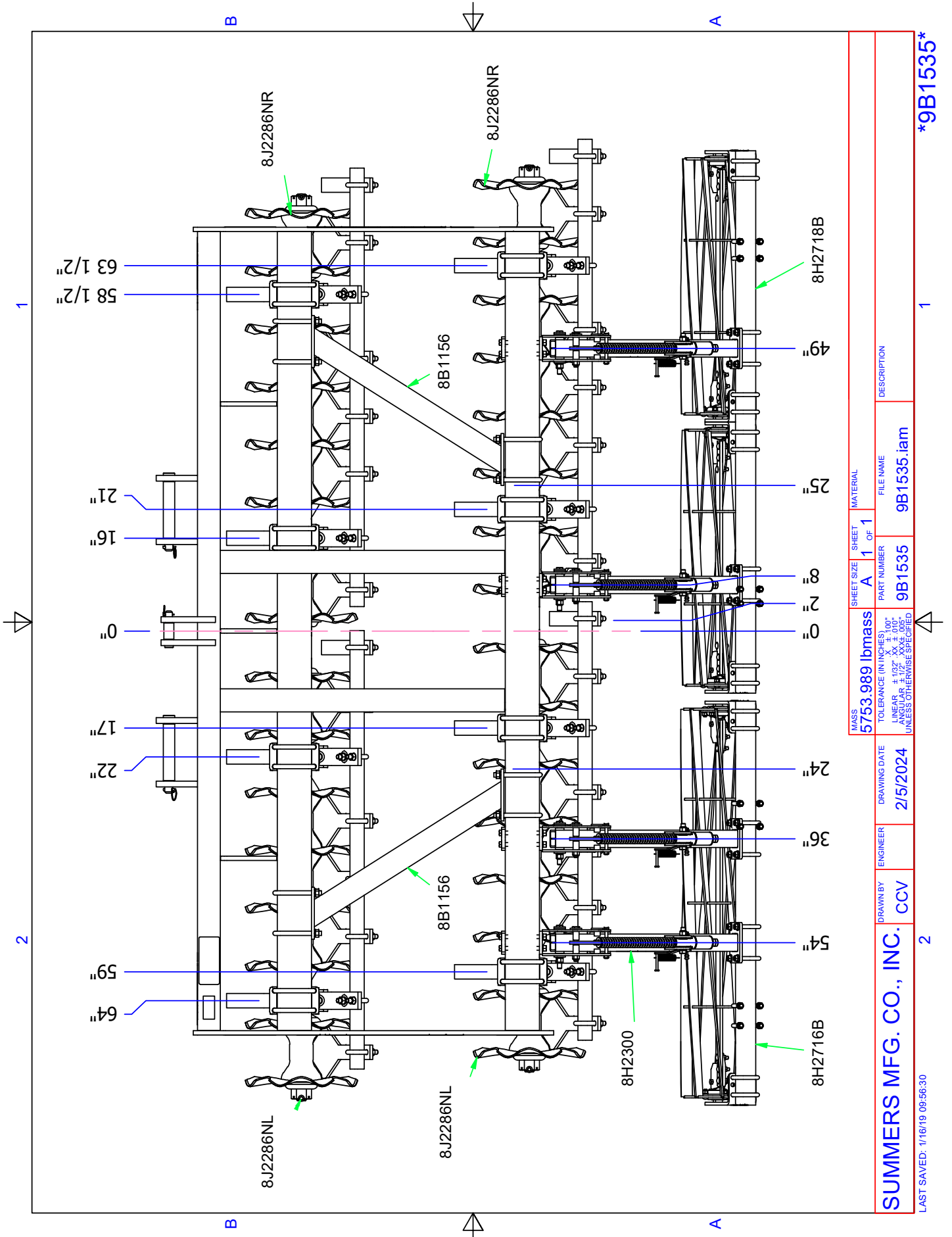

MASS	5753.989 lbmass	SHEET SIZE	A	SHEET	1	MATERIAL	
TOLERANCE (IN INCHES)	LINEAR ±.002" ANGULAR ±.004° UNLESS OTHERWISE SPECIFIED	DRAWING DATE	2/5/2024	OF	1	FILE NAME	9B1535.lam
<b>SUMMERS MFG. CO., INC.</b>		ENGINEER	CCV	PART NUMBER	9B1535	DESCRIPTION	
LAST SAVED: 1/16/19 09:56:30							

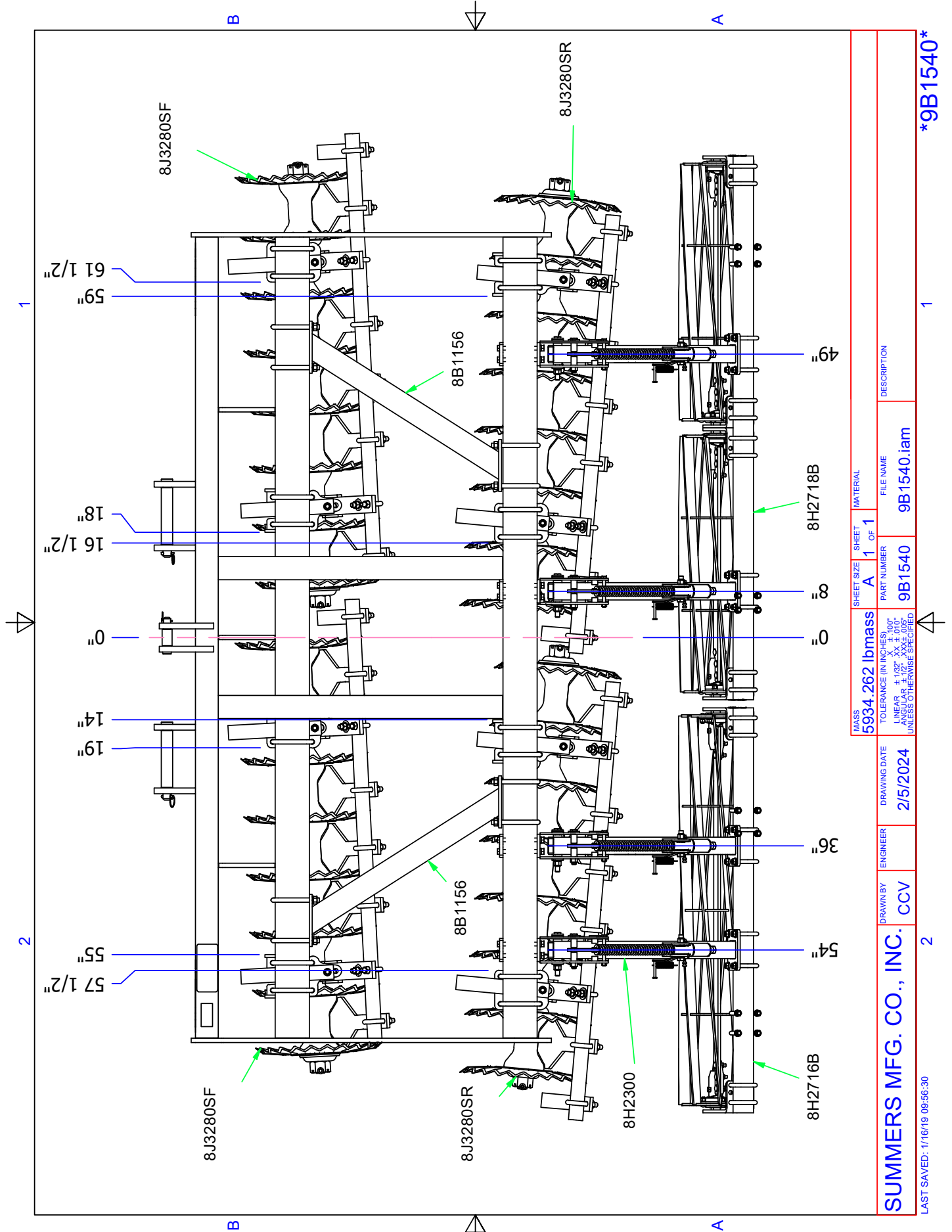

W/ASS	SHEET SIZE	SHEET	MATERIAL	DESCRIPTION
5934.262 lbmass	A	1	1	9B1540
TOLERANCE (IN INCHES):		FILE NAME		
LINEAR: ±.002" XX ±.00"		9B1540.iam		
ANGULAR: ±.05° XX ±.05°		PART NUMBER		
UNLESS OTHERWISE SPECIFIED		9B1540		
DRAWING DATE		DRAWING DATE		
2/5/2024		2/5/2024		
DRAWN BY		ENGINEER		
CCV		CCV		
SUMMERS MFG. CO., INC.		SUMMERS MFG. CO., INC.		
LAST SAVED: 1/16/19 09:56:30		LAST SAVED: 1/16/19 09:56:30		

### **Parts Ordering Procedure**

When ordering parts for your Summers 3RT Track Remover, please contact an authorized Summers dealer in your area. If the parts are associated with a possible warranty claim, make sure that you contact the original dealer from which you purchased the Summers implement. Make sure to provide the Summers implement model, Serial number, Part number, Part description and quantity.

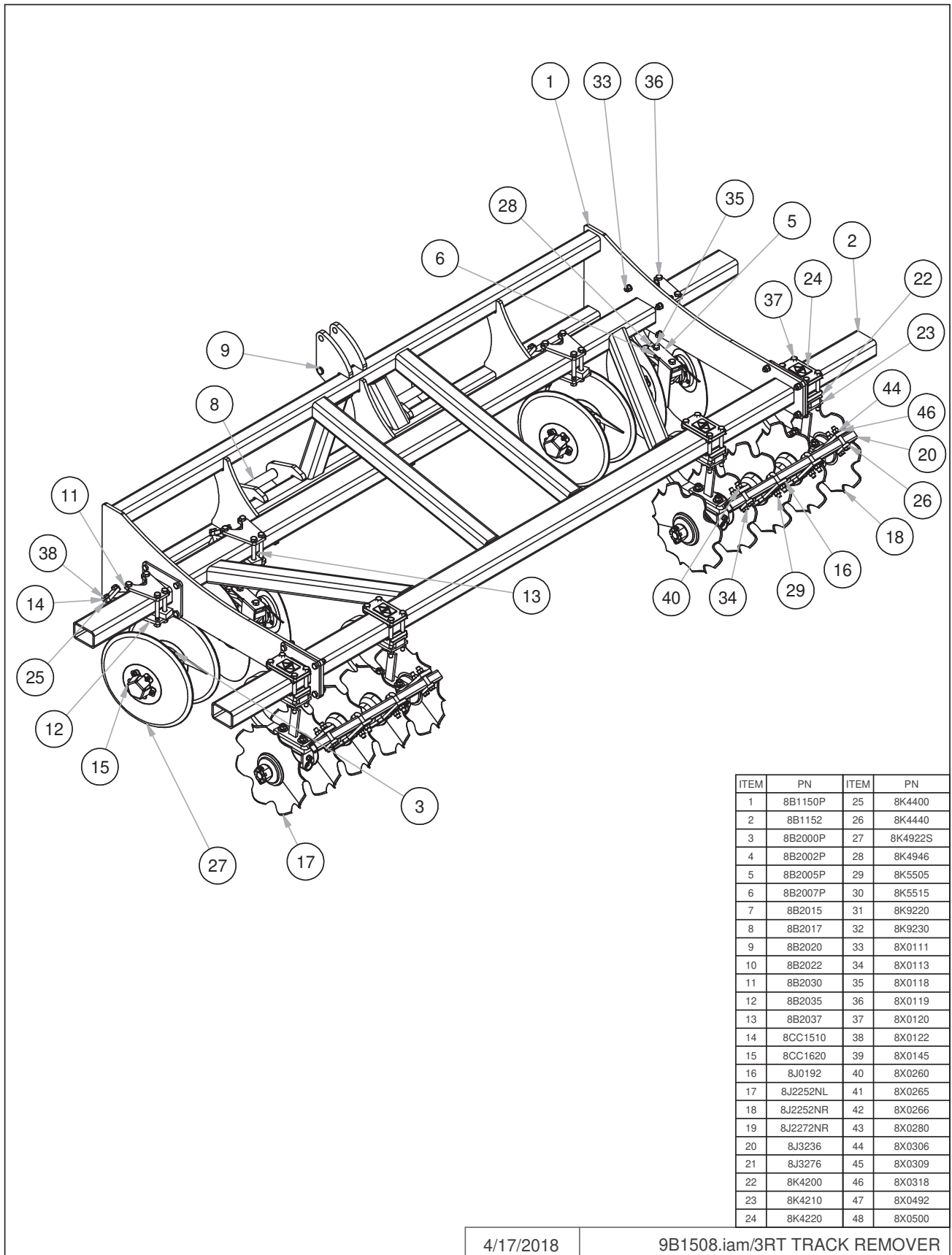

ITEM	PN	ITEM	PN
1	8B1150P	25	8K4400
2	8B1152	26	8K4440
3	8B2000P	27	8K4922S
4	8B2002P	28	8K4946
5	8B2005P	29	8K5505
6	8B2007P	30	8K5515
7	8B2015	31	8K9220
8	8B2017	32	8K9230
9	8B2020	33	8X0111
10	8B2022	34	8X0113
11	8B2030	35	8X0118
12	8B2035	36	8X0119
13	8B2037	37	8X0120
14	8CC1510	38	8X0122
15	8CC1620	39	8X0145
16	8J0192	40	8X0260
17	8J2252NL	41	8X0265
18	8J2252NR	42	8X0266
19	8J2272NR	43	8X0280
20	8J3236	44	8X0306
21	8J3276	45	8X0309
22	8K4200	46	8X0318
23	8K4210	47	8X0492
24	8K4220	48	8X0500

4/17/2018

9B1508.iam/3RT TRACK REMOVER

ITEM	PN
1	7B0210
2	7B0214
3	7CC0450
4	7K3862
5	8CC1592
6	8D5242
7	8D5246
8	8D5250
9	8K7343
10	8D5240
11	8D5244
12	8D5243
13	8CC1587
14	8D5247
15	8CC1615
16	8D5214
17	8K4400
18	8K4922S
19	8X0118
20	8X0119
21	8X0122
22	8X0260
23	8X0265
24	8X0306

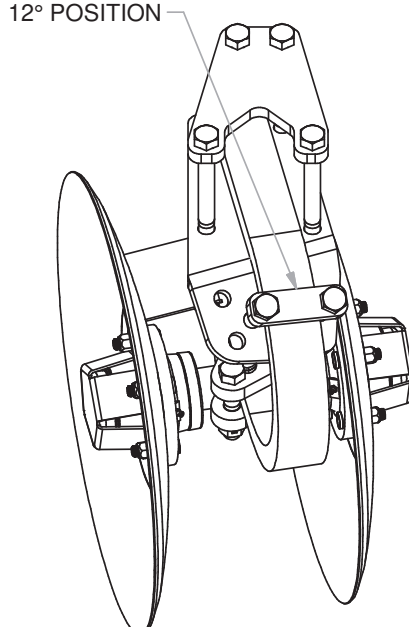
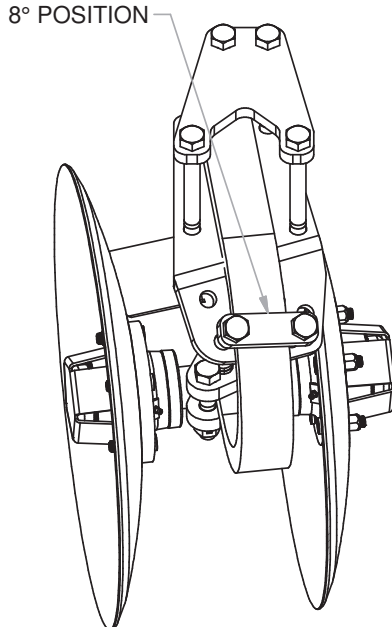
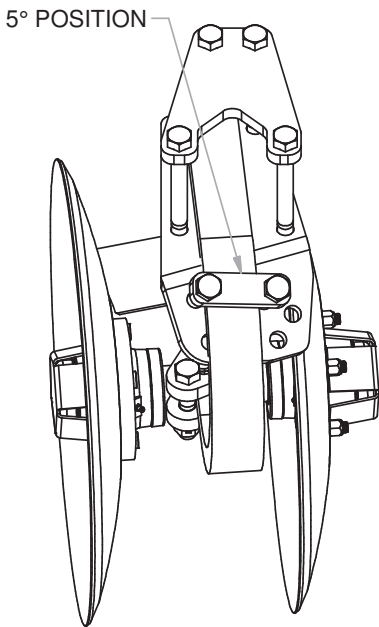
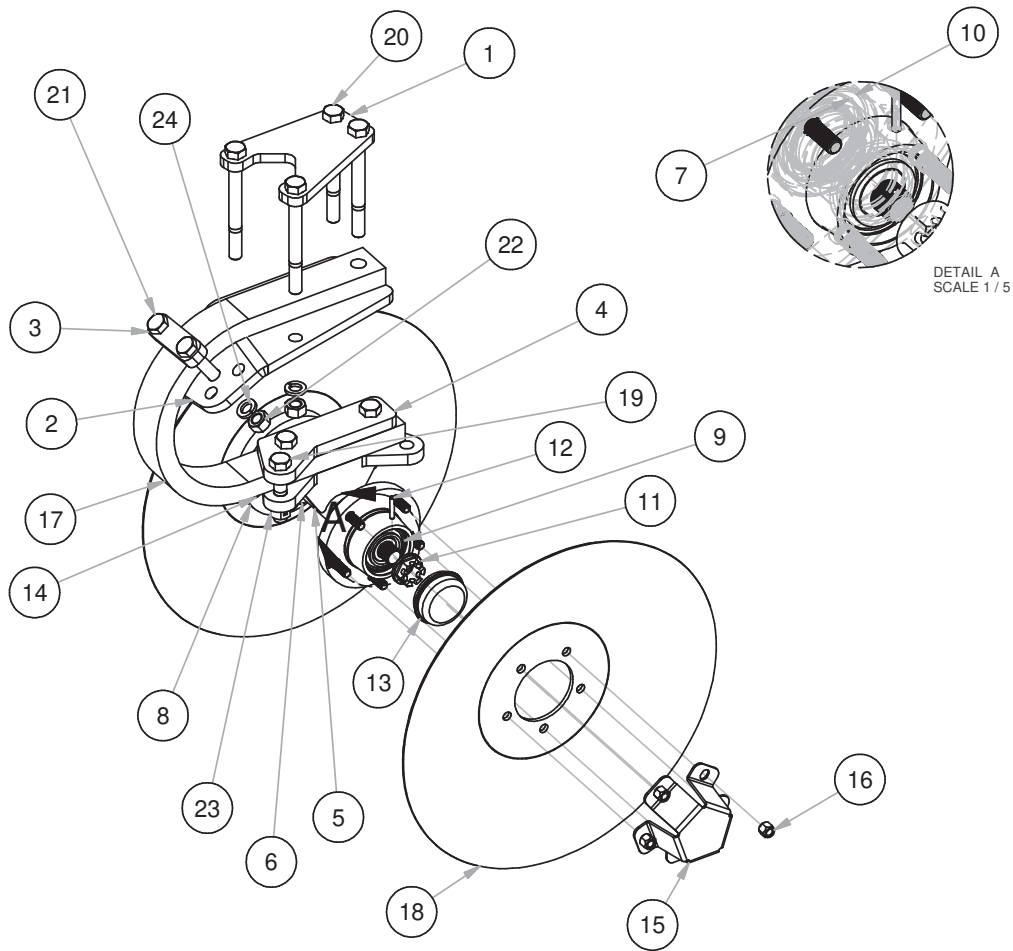

4/17/2018 3 RT TRACK REMOVER TWIN DISK

ITEM	PN
1	7B0210
2	7B0214
3	7CC0450
4	7K3862
5	8CC1587
6	8CC1592
7	8CC1615
8	8D5214
9	8D5240
10	8D5242
11	8D5243
12	8D5244
13	8D5246
14	8D5247
15	8D5250
16	8K7343
17	8K4400
18	8K4922S
19	8X0118
20	8X0119
21	8X0122
22	8X0260
23	8X0265
24	8X0306

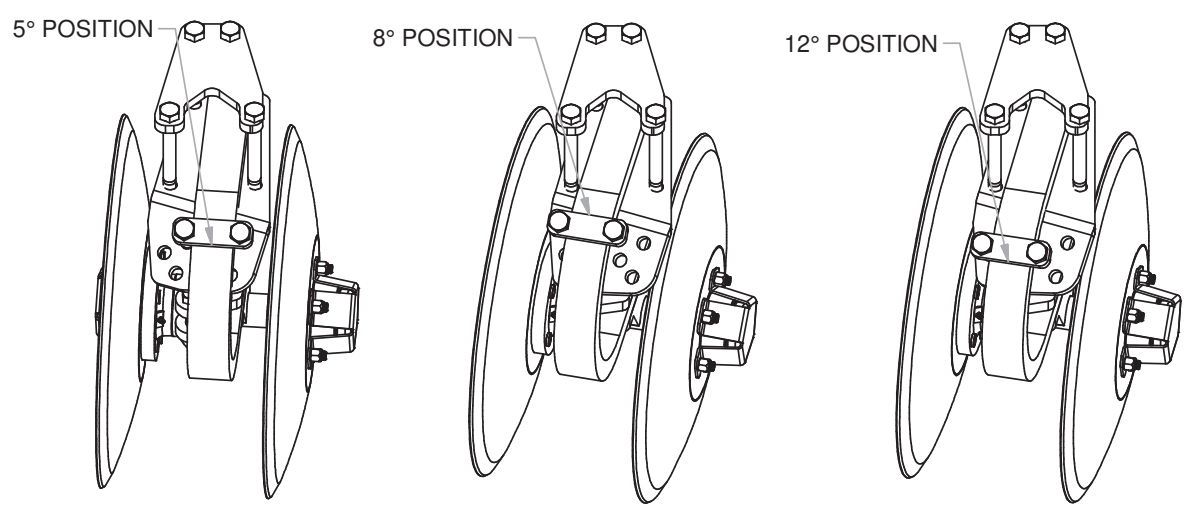
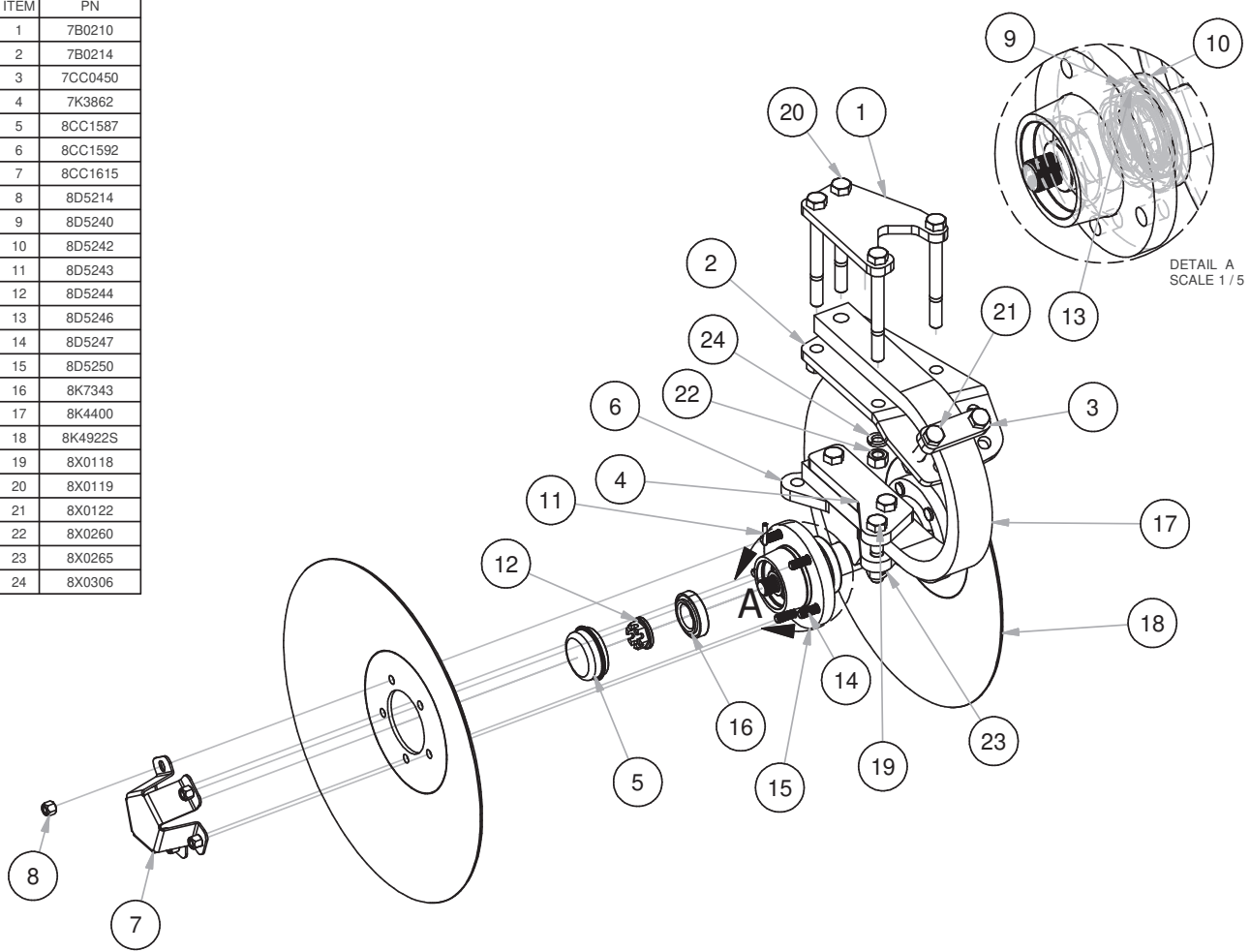

4/17/2018 3RT TRACK REMOVER TWIN DISK - LEFT

## GANG ASSEMBLY

### LEFT

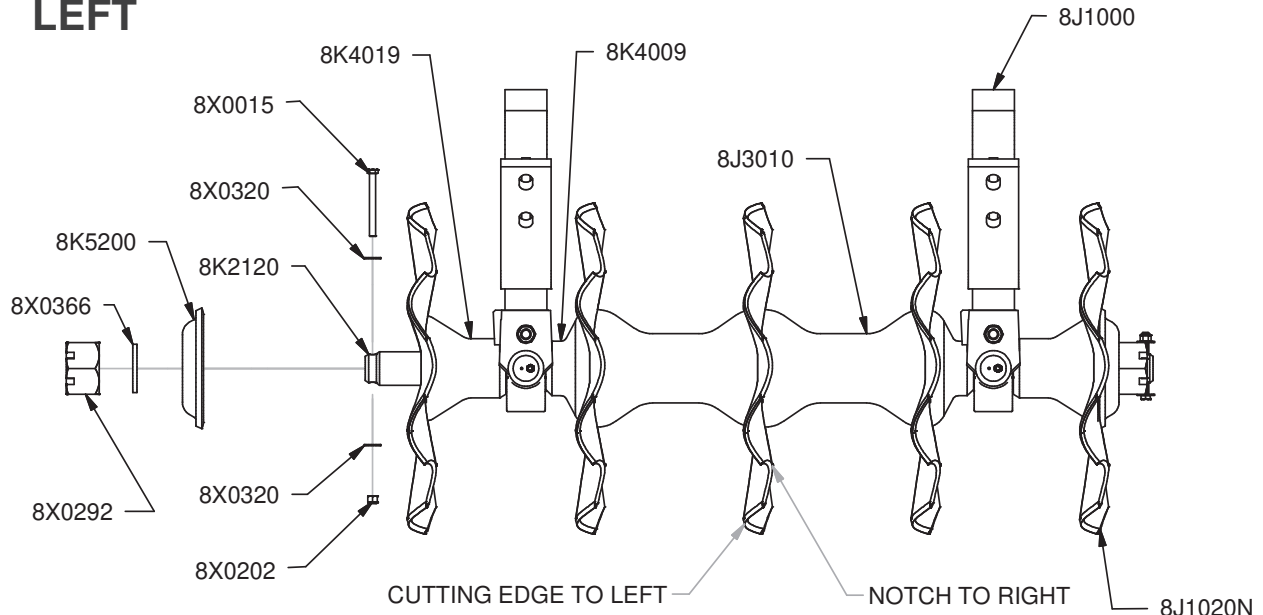

### RIGHT

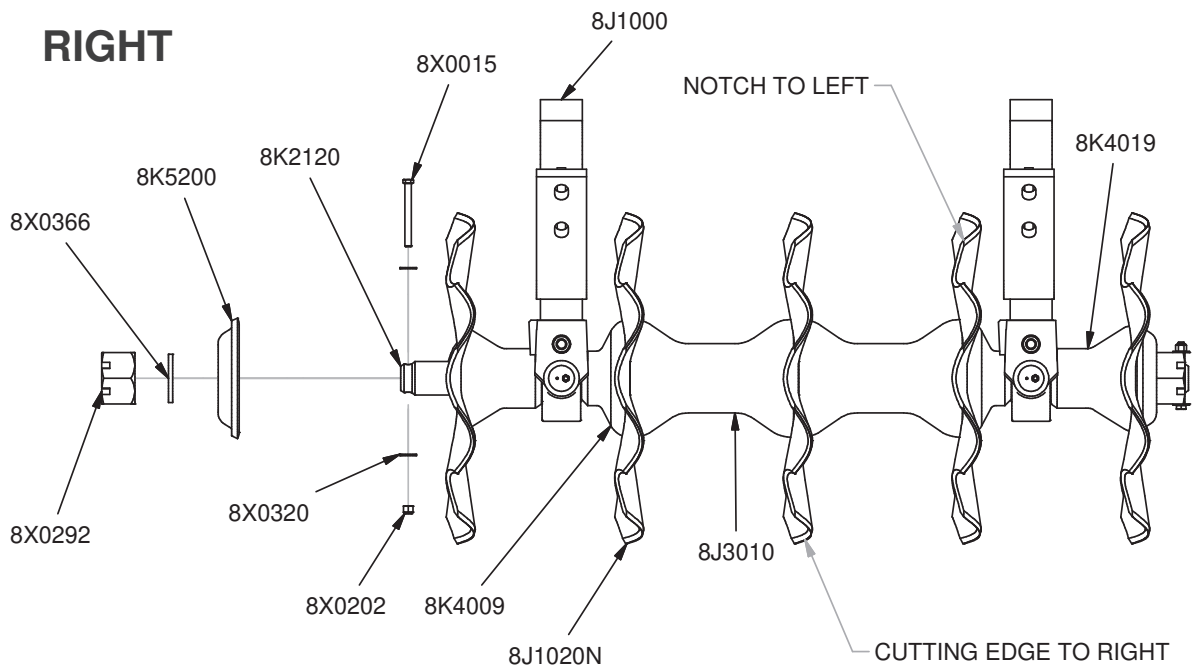

4/17/2018

GANG 5 BLADE - LFT AND RIGHT



# History of Summers Manufacturing Co., Inc.

- 1965 – Summers Manufacturing is founded by Harley Summers, who purchases patent rights for Goebel truck and pickup hoists from the Goebel Brothers of Lehr, ND. These hoists, produced in Harley Summers' blacksmith shop the first year, were distributed nationwide by a Cincinnati, Ohio, dealer. With increasing sales, the company soon outgrows the small shop. Summers wins the Herman harrow contract, beginning the company's Herman culti-harrow line. Summers builds a 7,200 square-foot factory in Maddock to meet the demand for truck and pickup hoists, as well as Herman harrows.
- 1969 – Firm incorporates and becomes officially known as Summers Manufacturing Company, Inc.
- 1970 – Summers purchases rights to manufacture/market the Herman Harrow.
- 1973 – Company builds new 20,000 square-foot plant and offices in Maddock, adding a 20,000 square-foot assembly plant in the fall of 1975 (completed in January 1976), bringing total square footage of Maddock factories to 47,000.
- 1977 – Summers introduces the Agri-sprayer, used in conjunction with the Herman culti-harrow to incorporate herbicides and liquid fertilizer.
- 1980 – Company purchases manufacturing and distributing rights to Crown rockpickers from Crown Manufacturers of Regina, Saskatchewan. This forces another expansion project – a 26,000 square foot factory on a 24 acre site in Devils Lake, ND Industrial Park.
- 1981 – Company establishes a branch facility in Regina, Saskatchewan.
- 1982 – Devils Lake plant begins operations in January, manufacturing supersprayers and rockpickers. The Maddock factory begins producing the Superweeder, a combination cultivator and harrow.
- 1983 – Summers buys manufacturing and distributing rights to the Fargo Field Sprayer line from Mid America Steel (formerly Fargo Foundry), Fargo. This field sprayer line is manufactured at the Devils Lake plant. Harley Summers is selected North Dakota's small-businessman of the year by the Small Business Administration.
- 1984 – Herman Diamond Disk, a disk harrow made in a diamond shape to reduce blade breakage from rocks, comes off the assembly line.
- 1985 – Summers signs a contract with Melroe Company of Bismarck to obtain exclusive manufacturing rights to the Melroe harrow line.
- 1989 – Summers purchases TorMaster Company of Hordean, Manitoba, giving the company a line of rolling packer equipment, comprised of harrow packers and hydraulic fold coil packers.
- 1992 – A new engineering office/parts department is added to the Devils Lake factory.
- 1993 – Company adds two new products: a pickup-mounted sprayer with booms of 80 and 90 feet, and the Summers Superharrow, an extra-heavy-duty residue-management tool designed for the minimum and no-till farmer.
- 1994 – a 50 by 125 foot addition to the Maddock factory is completed. Construction begins on a 24,576 square-foot addition to the Devils Lake factory, which enables the company to increase production of truck-mounted and pull-type supersprayers and rockpickers.
- 1996 – 1500 square foot office area added to the Maddock plant. Company introduces Chisel Plow with floating hitch and 700# trip assembly.
- 1997 – 16,800 square foot warehouse in Maddock purchased from local business.
- 1999 - Company introduces the Ultimate suspended boom trailer sprayer with hydraulic folding booms. Additional sizes added to the Chisel Plow line, now ranging from 28' to 54'.
- 2000 - Company introduces the Supercoultter, the innovative solution for excessive field residue management on no-till, minimum-till, and conventional-till farming operations.
- 2001 - Cold storage building completed at Devils Lake. Company extends boom lengths up to 110 feet on the Ultimate Supersprayer.
- 2002 - Company adds a warehouse and service man in Aberdeen, SD.
- 2003 - Company introduces the Ultimate NT Supersprayer featuring a bolt on axle for easier adjustment, and a new family of tanks that feature a drainable sump and a common width dimension.
- 2004 - A 124 ft. x 310 ft. addition is added onto the current Devils Lake plant.
- 2005 - The Summers Superroller is added to the "Field Tested Tough" product line. Additional sizes of 56', 58' and 60' are added to the Superchisel line. Ultimate-Ultra NT Supersprayer introduced featuring 120' & 133' booms.
- 2006 - The Summers Coulter-Chisel, Rolling Choppers and 30' Superroller were included in product line.
- 2007 - 62' & 84' 5 Section Landrollers and a 20' Coulter-Chisel were introduced.
- 2008 - Disk-Chisels, ranging from 16' to 40' widths, are added to product line.
- 2009 – M105 and M108 Mounted Harrows added to selection of Mounted Attachments. SuperHarrow 2650, 50' SuperCoulter, Hydraulic Fold Rolling Chopper and 36" diameter Landrollers introduced.
- 2010 – Rolling Basket and 47' Diamond Disk added to product line. A 124 ft. x 310 ft. addition to Devils Lake factory built for a state of the art paint system.
- 2011 – Additional Supercoulter sizes were added along with larger tires for tillage implements. Ultimate and Ultra Supersprayers received an additional tank size of 1650 gallons. Front Caster Wheel option was made available for chisel implements.
- 2012 – 41', 46' & 53' Trail Type Landroller added to product line. Additional Superchisel sizes of 16' & 20' were added.
- 2013 – DT9530 added to product line. Internal Scraper in Rolling Baskets introduced. Finishing Coulter Gang becomes standard on the Diamond Disk and 2510 DT. Corporate offices opened at Devils Lake plant. New building and location for the Aberdeen warehouse.
- 2014 – Introduced the VRT2530 (Variable Rate Tillage).
- 2015 – Introduced the VT Flex Applicator and Spray Fill Xpress. Expanded Landroller sizes to include 15' & 21'.
- Summers distributes on a wholesale level to dealers and distributors throughout markets in North Dakota, South Dakota, Minnesota, Montana, Iowa, Washington, Idaho, Oregon, Utah, Colorado, Kansas, Nebraska, Oklahoma, Texas, Manitoba, Saskatchewan, Alberta, British Columbia, Kazakhstan, Russia and Australia, making it an international company.

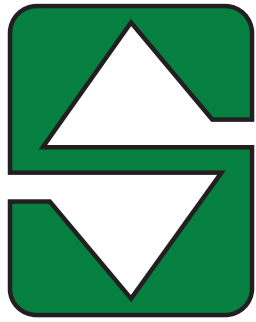

# **SUMMERS<sup>®</sup>**

*... Field Tested TOUGH!*



## Tillage

---



## Rock Picker

---



## Land Rollers/Packers

---



## Cultivators/Harrows

---



## Mounted Attachments

---



## Sprayers

---



1-800-732-4347 • [www.summersmfg.com](http://www.summersmfg.com)