

8Z1090 - Diamond Disk & 2510 DT

8Z1090 - Diamond Disk & 2510 DT

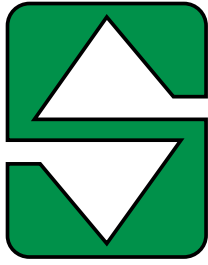

SUMMERS®

Operator's Manual



DK2610 & DT2510 (Diamond Disk & 2510 DT Series)

IMPORTANT

THE OPERATOR IS RESPONSIBLE FOR ADJUSTING THE MACHINE SINCE MACHINE DOES NOT COME "FIELD READY" FROM FACTORY.



CAUTION

READ & UNDERSTAND OPERATOR'S MANUAL BEFORE USING MACHINE.

See www.summersmfg.com for latest version of all Summers Operator's Manuals.

SUMMERS MANUFACTURING CO., INC.
WEB SITE: www.summersmfg.com

DEVILS LAKE, NORTH DAKOTA 58301

(701) 662-5391

TABLE OF CONTENTS

FOREWARD

Preface	5
Disclaimer	5
Contact Information	5
Owner Registration Information	5
Warranty	6

SAFETY

Safety Information.....	7
General Safety Practices	7
Safety During Transportation	7
Safety Decals.....	8
Safety Decal Locations	9
Safety Light Operation	12
General Maintenance Safety Practices	13

OPERATION

Connecting to Implement.....	15
Field Operation	16
Rear Coulter Gang.....	17
Transporting.....	18
Storage	18
Troubleshooting	19
Proper Bolt Use	20

PARTS

Hitch	23
Caster Wheel Hitch.....	24
18.5-32.5' Main Frame.....	25
Hydraulics 18.5-21.5'	26
Hydraulics 24.5-32.5'	27
Wing Fold Hydraulics 24.5-32.5'	28
38.5-44.5' Main Frame.....	29
47' Main Frame	30
Hydraulics 38.5-47'	31

Wing Fold Hydraulics 38.5-44.5'	32
Wing Fold Hydraulics 47'	33
Gang Assembly.....	34
Disk Coulter Assembly	35
Weight Package.....	36
Trip Assembly	37
Double Coulter.....	38
Center Blade.....	39
Rear Coulter Gang.....	40
Rear Coulter Gang Hydraulics.....	41-42
Safety Lights	43
Hub Assembly.....	44
614 Hub with GBGI Seal Assembly	45
Mounted Harrow Mounting Arm Assembly.....	46
3-Bar Mounted Harrow Assembly	47
Rolling Baskets Assembly.....	48
Hydraulic Rolling Baskets Assembly.....	49
Acre Meter	50
Part Numbers and Descriptions.....	51 - 54

TRANSPORT SAFETY

1. Road speed should not exceed 20 mph (32 km/hr).



2. Do not tow if the implement's towing vehicle ratio is greater than 1.5:1. See Specifications Section for implement weights.
3. If more than one implement is to be pulled by a towing vehicle, it is recommended that each implement is to be a maximum of 50% of the weight of the preceding implement. If it is not possible to reach this weight limit, transport the implements separately.
4. When approaching rough roads/ground (such as entering a road), slow down to a safe driving speed.
5. Check all lights and reflectors to ensure ALL regulations are met. Make sure the SMV emblem is attached to the implement and is clearly visible from the rear.



SMV emblems are only attached to vehicles traveling slower than 25 mph (40 km/hr). The most hazardous conditions to drive in are a daybreak and dusk. The use of a pilot car is recommended.

6. Always install ALL safety locks before transporting an implement.
7. Always park implements on a firm, level surface.

Preface

This manual is intended for use with Diamond Disk (DK2610) or 2510 DT (DT2510) for Summers® Manufacturing Company, Inc.

This book is composed of these basic sections: Safety, Operation & Maintenance, Troubleshooting and Parts. The safety section provides complete instructions for the proper safe operation of a Summers Mfg. product. The Operation & Maintenance section provides information for the proper operation and maintenance. A complete parts breakdown is provided in the Parts section.

Parts are referenced in each drawing with the Summers Manufacturing part number. Use this part number when ordering replacement parts from your Summers dealer. See the back section of the manual for description of each part.

Reference to “Right” and “Left” in this book is determined when the machine is viewed from the rear.

Disclaimer

It is the policy of this company to improve its products whenever possible and practical to do so. We reserve the right to make changes or improvements in the design or construction of parts at any time without incurring the obligation to install such changes on products previously delivered.

Summers Manufacturing Company, Inc. strongly recommends that each operator READ and UNDERSTAND the Operator’s Manual before using the machine. In addition, the Operator’s Manual should be REVIEWED at least Annually thereafter.

Contact Information

Summers Manufacturing Company, Inc.
103 Summers St. NW
Devils Lake, ND 58301
Toll Free: 1-800-732-4392
Local: 1-701-662-5391 (Devils Lake, ND)
1-605-226-3644 (Aberdeen, SD)
www.summersmfg.com

*Scan code below for
the latest version of all
Summers Operator’s Manuals.*



Owner Registration Information

Bring this information when ordering parts (Serial Number is located at front of hitch).

Name _____
Address _____
City _____
State/Prov. _____
Mail Code _____

Size _____
Serial Number _____
(located by the hitch)
Date Purchased _____
Dealer _____

WARRANTY

Summers warrants only products of its manufacture against operational failure caused by defective materials or workmanship which occur during normal use within 36 months from the date by the end user from Summers' dealer.

Summers' obligation is to replace, free of charge, any part of the product that Summers inspection shows to be defective excluding transportation charges to Devils Lake, ND and return and also excluding all transportation costs from Summers' dealer to the dealer's customer and all other costs, such as removal and installation expense.

Summers shall not be liable for loss of time, manufacturing costs, labor, material, loss of profits, consequential damages, direct or indirect, because of defective products whether due to rights arising under the contract of sale or independently thereof, and whether or not such claim is based on contract, tort or warranty.

Written permission for any warranty claim return must be first obtained from authorized Summers' personnel. All returns must be accompanied with a complete written explanation of claimed defects and the circumstances of operational failure.

Written warranty for all component parts used in the manufacture of Summers products is available upon request. Warranty of such component parts will be determined by said component manufacturer upon their inspection of the claimed defective part.

This express warranty is the sole warranty of Summers. There are no warranties, which extend beyond the warranty therein expressly set forth. The sales for products of Summers under any other warranty or guarantee express or implied is not authorized. This warranty voids all previous issues.

Summers® Manufacturing Co., Inc.
Devils Lake, ND 58301

01/16

Safety Information



This safety alert symbol is used to denote possible danger and care should be taken to prevent bodily injury. When you see this symbol it means ATTENTION, BECOME ALERT! and/or YOUR SAFETY IS INVOLVED!

WARNING: Safe practices must be followed when working on or operating this equipment. All personnel involved must:



- Read and understand the instructions and manuals for this machine.
- Be instructed in the safe use of tools and all lifting devices involved in the assembly of this equipment.
- Clear the area of all personnel not involved in the assembly of this machine.

General Safety Practices

1. READ and UNDERSTAND the Operator's Manual before using any equipment. Review at least annually thereafter.
2. VERIFY all safety devices and shields are in place before using any equipment.
3. KEEP hands, feet, hair and clothing away from moving parts.
4. STOP engine, place all controls in neutral, set parking brake, remove ignition key and wait for all moving parts to stop before servicing, adjusting, maintaining or unplugging.
5. BE CAREFUL when working around high pressure hydraulic system.
6. DO NOT ALLOW RIDERS.

Safety During Transportation

1. ONLY TOW at a safe speed. Use caution when making corners and meeting traffic.
2. USE safety chain between tractor drawbar and implement hitch when transporting on public roads.
3. ALWAYS use transport locks when transporting on public roads.
4. COMPLY with local lighting, marking and oversize regulations when transporting on highways.
5. FREQUENTLY check for traffic from rear, especially during turns.

Safety Decals



Indicates an immediate hazardous situation that will result in death or serious injury. The color associated with Danger is RED.



Indicates a potentially hazardous situation that could result in death or serious injury. The color associated with Warning is ORANGE.



Indicates a potentially hazardous situation that may result in minor or moderate injury. It may also be used to alert against unsafe practices. The color associated with Caution is YELLOW.

The Notice decals and statements in this manual are to inform the operator of the correct fluids or operational practices for this machine. Failure to follow these notices will result in damage to the machine. The color associated with Notice is GREEN.

1. Keep safety signs clean and legible at all times.
2. Replace safety signs that are missing or have become illegible.
3. Replaced parts that displayed a safety sign should also display the current sign.
4. Safety signs are available from your dealer's parts department or the factory.

How to install safety signs?

1. Be sure that the installation area is clean and dry.
2. Be sure the temperature is above 50° F (10° C).
3. Decide on the exact position before removing the backing paper.
4. Remove the smallest portion of the split backing paper.
5. Align the sign over the specified area and carefully press the small portion with the exposed sticky backing in place.
6. Slowly peel back the remaining paper and carefully smooth the remaining portion of the sign in place.
7. Small air pockets can be pierced with a pin and smoothed out using the piece of sign backing paper.

Safety Decal Locations



The types of safety signs and locations on the equipment are shown in the illustrations below. Good safety requires that you familiarize yourself with the various safety signs, the type of WARNING and the area or particular function related to that area, that requires your SAFETY AWARENESS.

IMPORTANT: If Safety Signs have been damaged, removed, become illegible or parts replaced without safety signs, new signs must be applied. New safety signs are available from your authorized dealer.



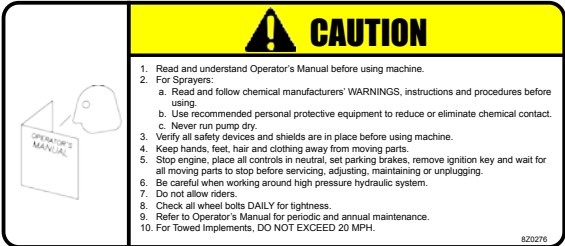
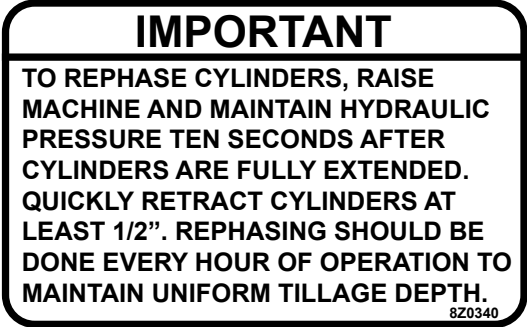

Safety Decals

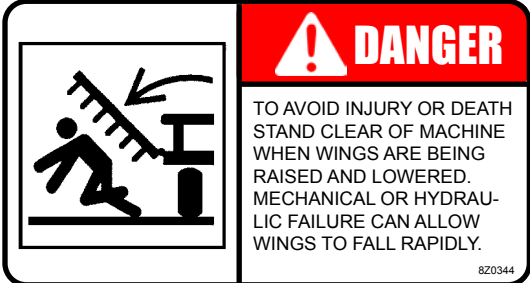
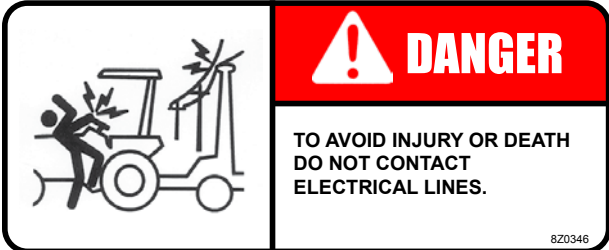
DECALS				
ITEM	PN	QTY	DESCRIPTION	
1	8Z0075	1	TRANSPORT LOCK DECAL	
2	8Z0087	4	PINCH POINT DECAL	
3	8Z0100	1	MADE IN THE USA DECAL	
4	8Z0202	4	3.5" SUMMERS DECAL	
5	8Z0204	2	5.5" SUMMERS DECAL	

Safety Decal Locations (cont'd)

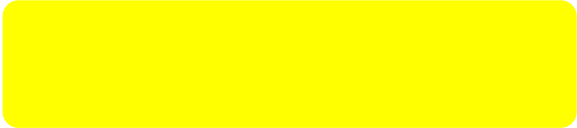
6	8Z0276	1	GENERAL MACHINE CAUTION DECAL	 <p>CAUTION</p> <ol style="list-style-type: none"> 1. Read and understand Operator's Manual before using machine. 2. For Sprayers: <ol style="list-style-type: none"> a. Read and follow chemical manufacturers' WARNINGS, instructions and procedures before using. b. Use recommended personal protective equipment to reduce or eliminate chemical contact. c. Never run pump dry. 3. Verify all safety devices and shields are in place before using machine. 4. Keep hands, feet, hair and clothing away from moving parts. 5. Stop engine, place all controls in neutral, set parking brakes, remove ignition key and wait for all moving parts to stop before servicing, adjusting, maintaining or unplugging. 6. Be careful when working around high pressure hydraulic system. 7. Do not allow riders. 8. Check all wheel bolts DAILY for tightness. 9. Refer to Operator's Manual for periodic and annual maintenance. 10. For Towed Implements, DO NOT EXCEED 20 MPH. <p>8Z0276</p>
7	8Z0340	1	REPHASING CYLINDERS DECAL	 <p>IMPORTANT</p> <p>TO REPHASE CYLINDERS, RAISE MACHINE AND MAINTAIN HYDRAULIC PRESSURE TEN SECONDS AFTER CYLINDERS ARE FULLY EXTENDED. QUICKLY RETRACT CYLINDERS AT LEAST 1/2". REPHASING SHOULD BE DONE EVERY HOUR OF OPERATION TO MAINTAIN UNIFORM TILLAGE DEPTH.</p> <p>8Z0340</p>
8	8Z0342	3	INSTALL CYL LOCKS DECAL	 <p>WARNING</p> <p>TO AVOID INJURY INSTALL CYLINDER LOCKS BEFORE TRANSPORTING OR SERVICING MACHINE.</p> <p>8Z0342</p>
9	8Z0344	4	WING DANGER DECAL	 <p>DANGER</p> <p>TO AVOID INJURY OR DEATH STAND CLEAR OF MACHINE WHEN WINGS ARE BEING RAISED AND LOWERED. MECHANICAL OR HYDRAULIC FAILURE CAN ALLOW WINGS TO FALL RAPIDLY.</p> <p>8Z0344</p>
10	8Z0346	1	ELECTROCUTION-TILLAGE EQUIP. DECAL	 <p>DANGER</p> <p>TO AVOID INJURY OR DEATH DO NOT CONTACT ELECTRICAL LINES.</p> <p>8Z0346</p>

Safety Decal Locations (cont'd)

11	8Z0350	4	GANG BEARING GREASE DECAL	<div style="border: 1px solid black; padding: 5px;"> <p align="center">IMPORTANT</p> <p>*GREASE GANG BEARINGS EVERY 20 HOURS.* GREASE AT MID DAY OR END OF DAY WHEN BEARINGS ARE AT OPERATING TEMPERATURE. ADD 3 STROKES OF CHEVRON ULTRA-DUTY EP NLGI 2 OR EQUIVALENT. ROTATE GANG 2 TO 3 REVOLUTIONS. ADD THREE MORE STROKES. GREASE ALL ZERKS ON MACHINE BEFORE EXTENDED STORAGE PERIOD.</p> <p align="right"><small>8Z0350</small></p> </div>
12	8Z0800	4	REFLECTOR - YELLOW - ADHESIVE BACKED	
13	8Z0805	4	REFLECTOR - RED-ORANGE ADHESIVE BACKED	
14	8Z0810	6	REFLECTOR - RED - ADHESIVE BACKED	
15	8Z2250 8Z2255 8Z2270 8Z2290	2	DK/DT DECAL	

Safety Light Operation

Figure 1

The Summers Safety Light Kit is equipped with a 7 pin connector which meets SAE J560 specification. To protect 7 pin connector, store in dust cap (8K8067) when not attached to towing vehicle.



General Maintenance Safety Practices

NOTE: Read the entire section before beginning work.

Before You Begin

- **YOU ARE RESPONSIBLE** for the safe maintenance of the equipment.
- **DO NOT ALLOW CHILDREN** or other unauthorized persons within the equipment's operational area.
- **WEAR PERSONAL PROTECTIVE EQUIPMENT** which includes a hard hat, eye protection, work gloves and steel toed boots with slip resistant soles.
- **DO NOT MODIFY** the equipment or substitute parts in any way. Unauthorized modifications may impair the function and/or safety of the machine.
- **USE SUITABLE LIFTING DEVICE** for components which could cause personal injury.
- **BLOCK UP ANY RAISED PART** of the machine. Be sure machine is stable after blocking.
- **ALWAYS INSPECT LIFTING CHAINS AND SLINGS** for damage or wear.
- **BE SURE LIFTING DEVICE IS RATED TO HANDLE THE WEIGHT.**
- **STOP ENGINE**, place all controls in neutral, set parking brake, remove ignition key and wait for all moving parts to stop before servicing or adjusting.
- **BE SURE PRESSURE IS RELIEVED** from hydraulic circuits before servicing or disconnecting from tractor.
- **USE EXTREME CARE** when assembling, servicing or adjusting.



START-UP AND HYDRAULIC OPERATION

INITIAL START UP PROCEDURE FOR DISK LIFT HYDRAULIC CYLINDERS

This disk has a Master-Slave Hydraulic Lift System. Fully extend hydraulic cylinders and maintain hydraulic pressure for 30 seconds to insure all air is purged from system. See diagram on previous page.

NOTE: As oil is pumped into the base end of master cylinder, oil is forced out of the rod end into the base end of each slave cylinder. To compensate for the smaller volume of oil in the rod end of the master cylinder, each slave cylinder is 1/2" smaller in diameter. When cylinders are fully extended, oil will bypass through a rephasing slot on each cylinder in order to equalize the system. The tractor SCV lever must be held for a few seconds to accomplish this passage of oil through the system.

INITIAL START-UP PROCEDURE FOR WING LIFT HYDRAULIC CYLINDERS

The wing lift hydraulic cylinders on this disk must be charged with oil before attempting to raise the wings.

The best method of performing this is to disconnect the rod end of the fold cylinders from the wings and connect the hoses to the tractor's couplers. Make sure the tractor reservoir is full of manufacturer's recommended hydraulic oil. Extend and retract the cylinders until the action is positive and all air is purged from the system. Due to the amount of oil required to fill the cylinders and lines, additional hydraulic oil may be required. After cylinders have been filled with oil, reconnect the rod ends of the cylinders to the wings.



CAUTION: Stand clear whenever raising or lowering the wings.

GANG BEARINGS:

Note: Zerks are installed on both front and back of gang bearing cast holders for your convenience. Both zerks lead to the bearing, only one needs to be greased.

To prevent contamination, insure that coupler and zerk are clean.

To maximize bearing life, grease bearings at mid day or end of day when bearings are at operating temperature.

Every 20 hours: Add three strokes (approx. .14 oz.) of grease to gang bearing. Rotate gang 2 to 3 revolutions. Add an additional three strokes of grease.

GENERAL:

Daily: Grease all pivot points located on wing lift, disk lift arms, and hitch.

Check all wheel bolts/nuts for tightness. Recommended torque

Before lowering the wings, remove the safety lock pins and place them in the storage positions. After wings are lowered, extend cylinders fully.

BEFORE INITIAL OPERATION

1. After receiving or assembling your disk, it is a good practice to double check entire machine so that all bolts are securely tightened.
2. Make sure all grease fittings are in place and greased properly.
3. Inflate all lift tires to the recommended inflation pressure and check wheel bolts. (See Maintenance for specifications.)

AFTER FIRST TWO HOURS OF OPERATION

1. Recheck wheel bolts for tightness and tighten spindle nuts if any side-play is evident in the bearings.
2. Check gang shafts for tightness. This procedure should be repeated daily through the first twenty hours of operation. Gang shafts should be tightened to 1200 foot-pounds.

NOTE: A 1/4" spacer (PN 8X0366) is available and should be installed when the castle nut has been tightened past lock bolt.

3. Bearing and C-shaped shank mounting bolts should be checked for tightness. This procedure should also be repeated daily during the first twenty hours of operation.
4. The scrapers on your disks should be checked and tightened if needed. Scrapers may have to be adjusted periodically to account for wear and different field conditions.

MAINTENANCE

listed below:

Hub	Wheel Bolt/Nut Torque
614 – 6 Bolt	170 ft-lb
812 – 8 Bolt	240 ft-lb
817 - 8 Bolt	240 ft-lb

Tighten spindle nuts if any side-play is evident in the bearings.

Maintain disk gang torque at 1200 ft. lb.

Seasonally: Clean and repack wheel bearings.

TIRE INFLATION:

Recommended tire inflations listed below:

Size	Ply	Pressure
11L x 15	LRF	85 psi
12.5L x 15	LRF	90 psi
340/65R18	148A8	78 psi

FIELD OPERATION

The following procedure should be used for field operation of your Summers Diamond Disk & 2510 DT.

1. Remove wing safety lock pins and transport locks and place in their storage positions.
2. Lower wings for field operation.
3. Level disk. The disk should be adjusted in a level area of the field.

IMPORTANT!

All pressure must be removed from cylinders before adjusting eyebolts. Rest Disk on top of the ground, shut tractor off and relieve pressure by cycling remote lever.

- A. First, level the center section (front to rear) by adjusting the threaded eye bolts located above each hydraulic cylinder.
- B. Second, level the wings with the center section again by adjusting the threaded eye bolt above each hydraulic cylinder.
- C. With the front center cylinder in the rear hole, after the disk has been leveled in working position, it is normal for the front gangs to be 3-4" lower than the rear gangs in the fully raised position. This is due to the fact that when the disk is in working position, the front center tires run on top of a ridge of soil thrown in by the front gangs.

18-1/2' and 21-1/2' Machines

To set depth, install stroke control collars on the front center cylinder (5" dia. x 10" stroke).

24-1/2' - 47' Machines

After determining desired tillage depth, set depth control plunger accordingly. Standard plunger hole spacing gives 5/16" cylinder stroke adjustment. By rotating plunger 90 degrees, a half step adjustment can be achieved. See drawing below.

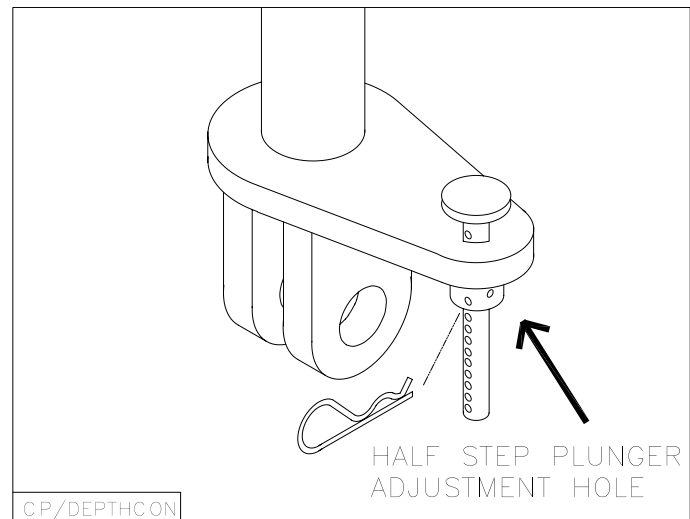
⚠ WARNING

**TO AVOID INJURY
INSTALL CYLINDER
LOCKS BEFORE
TRANSPORTING OR
SERVICING MACHINE.**

8Z0342

IMPORTANT

TO REPHASE CYLINDERS, RAISE MACHINE AND MAINTAIN HYDRAULIC PRESSURE TEN SECONDS AFTER CYLINDERS ARE FULLY EXTENDED. QUICKLY RETRACT CYLINDERS AT LEAST 1/2". REPHASING SHOULD BE DONE EVERY HOUR OF OPERATION TO MAINTAIN UNIFORM TILLAGE DEPTH .

8Z0340

REAR COULTER GANG

IMPORTANT: Rear coultter gang is designed to work with active hydraulic down pressure. See note on Page 42 to configure to either closed-center or open-center hydraulic system tractors.

1. Plug rear coultter gang hydraulic hoses into desired tractor outlet. Insure that tips and couplers are clean. At the tractor, adjust hydraulic flow to 30% of maximum and to constant vs. timed output.
2. Do not allow anyone to stand near rear coultter gang when raising or lower. Lower rear coultter gang with tractor hydraulics and engage circuit in lower position, do not run this hydraulic circuit in neutral/locked position. Adjust rear coultter gang down pressure with base end regulator to 500 PSI.
3. Work a test strip in your field. Insure that the DK/DT is tilling at an equal depth across machine width. Check penetration depth of rear coultter blades, regulator valve pressure can be adjusted lower or higher to maintain effective cutting depth. Maximum regulator pressure is 1500 PSI.

IMPORTANT: Damage to DK or DT and rear coultter gang may occur if run with hydraulic circuit in neutral/locked position. Damage caused by running with hydraulic circuit in neutral/locked position is not covered by Summers warranty.

Monitor temperature of tractor hydraulic oil. Discontinue use of rear coultter gang live hydraulic down pressure if hydraulic oil becomes excessively hot. If this occurs, run rear coultter gang hydraulic circuit in Float Position Only until cause of overheating is resolved. Contact your Summers Dealer for troubleshooting information. Damage caused by overheating of tractor hydraulic system is not covered by Summers warranty.

4. If the soil profile behind the rear coultter gang shows a valley or depression, not enough soil is flowing between the rear center blades. Lower the front of the DK/DT to increase the amount of soil running thru the implement center.

If a mound of soil appears behind the rear coultter gang, too much soil is flowing between the rear center blades. Raise the front of the DK or DT to reduce the amount of soil running thru the implement center.

5. If equipped with Adjustable Rear Coultter Gang, fine tuning can be accomplished by changing the angle of the coultter gangs. Rotating the crank handle counter-clockwise will increase the gang angle, resulting in the coultter blades pulling more soil away from center strip. Rotating the crank handle clockwise will decrease (straighten) the gang angle, resulting in less soil movement.



TRANSPORTING

The Summers Diamond Disk & 2510 DT are equipped with manual wing and center lift cylinder locks. The following procedure should be used to prepare disk for transport.

1. Check that wing locks are in the storage positions.
2. Fully extend main lift cylinders, quickly lower disk approximately 1", raise wings.
3. Install safety locks on wings and center lift cylinders.
4. USE a safety chain between tractor drawbar and disk hitch when transporting on public roads.
5. Check wheel bolts / nuts after first 20 miles of road transport and every 60 miles there after.

Road the implement at a reasonable speed not to exceed 20 miles per hour.

Always use an ASAE "Slow Moving Vehicle" emblem and Safety Lights when transporting on a road or highway. Comply with your state and local laws governing lighting and maximum width regulations. Transport during daylight hours only.

NOTE: Because of the tricycle tire arrangement of the disk center section, the front set of duals tend to "scuff" during sharp turns on hard surfaces such as concrete or pavement.

Avoid very sharp turns with disk at all times. If necessary to make a sharp turn, do so with wings down and proceed slowly.

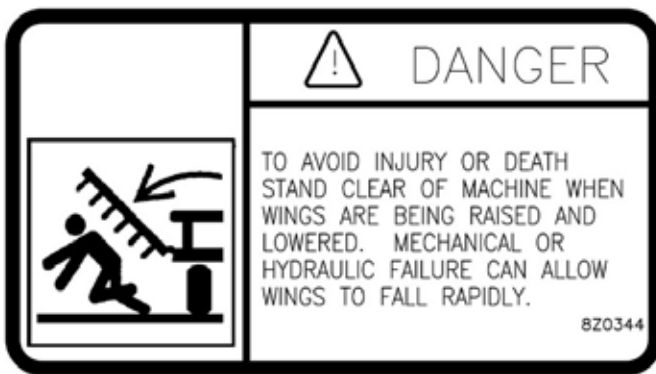

STORAGE

Proper rust prevention treatment of equipment before placing in storage will not only lengthen its useful life, but will assist in maintaining optimum performance when put back into service.

The following list contains suggestions for preparing your implement for storage.

1. Clean entire machine. Remove all dirt and excessive grease implement.
2. Check disk over thoroughly for damaged or worn parts, cracked or broken blades, and loose bolts.
3. Wheel bearings should be cleaned and repacked each year.
4. Grease all zerks on implement.
5. Block up to remove weight from tires.
6. If implement is lowered to the ground, place boards under blades.
7. Disconnect rods and fully retract the cylinders to prevent rusting of shafts and subsequent seal damage. If left extended, coat rods with grease to prevent corrosion. Remove grease prior to retracting cylinders.
8. For safety, do not store implement with wings folded up.
9. Clean and place a protective coating of heavy oil or grease on earth-working parts to prevent rusting.
10. Touch-up any spots where paint has been scratched or worn off.

TROUBLESHOOTING

NO.	PROBLEM	CAUSE	CORRECTION	PAGE
1	Trash buildup ahead or behind chisel plow shank.	Working in unusually heavy trash.	Check that cross tube (8HD5150) is rotated to provide maximum clearance between shank and harrow.	47
			Install Coulter Option (8K6890)	35
			Harrow section can be lifted and "locked" up if conditions require.	46
2	Leaving center valley	Rear gangs cutting too deep.	Level disk using threaded adjustment bolts above each cylinder/wheel assembly.	16
			Diamond Disk - Install additional 2 8K5025N blades at rear center.	34
3	Gangs plugging.	Extremely wet field conditions.	Allow to dry if possible.	
		Scrapers adjusted improperly.	Adjust scrapers so scraping edge is flush against each blade, but not tight enough to prevent gang from turning freely.	15
			Under some soil and residue conditions, scrapers will perform better if set 1 to 1-1/4" away from blades.	
			Adjust machine to run rear gangs deeper.	16
4	Poor penetration, center section.	Disk not running level from front to rear.	Level disk using threaded adjustment bolts above each cylinder/wheel assembly.	16
		Wheels are holding disk out of the ground.	Retract hydraulic cylinders for desired depth.	16
5	Hydraulic cylinders not synchronized.	Hydraulics have drifted or air has entered the system.	Hold hydraulic control lever with the hydraulic cylinders fully extended 15 seconds to synchronize rephasing cylinders.	15-16
6	Leaving ridge 2-4 feet from disk center.	Side draft.	Level disk using threaded adjustment bolts above each cylinder/wheel assembly.	16
			Recheck gang spacing.	
7	Plugging at disk front center.	Wet conditions or extremely high residue conditions.	Diamond Disk - Replace front center blades with 8K5025N notched blade.	34
			Install second stalk fingers 180 degrees from standard on front center gangs. Order 2: 8X0257 and 2: 8K5214.	34
8	Wings do not penetrate.	Dry/hard conditions.	Adjust wing cylinders to lift wheels off ground.	16
			Add 8K9250 Wing Wt. Package or 8K9252 Double Weight Package.	36
9	Gang bolts do not stay tight.	Gangs have run loose for extended time.	Disassemble gang, clean and replace worn components.	34

PROPER BOLT USE

DO NOT use these values if a different torque value or tightening procedure is given for a specific application. Torque values listed are for general use only. Check tightness of fasteners periodically.

BOLT SIZE	WRENCH SIZE	GRADE 5		GRADE 8	
		ft-lbs	N • m	ft-lbs	N • m
1/4"	7/16" or 3/8"	7	9.5	12	17
5/16"	1/2"	15	20	25	34
3/8"	9/16"	30	41	45	61
7/16"	5/8" or 11/16"	45	61	70	95
1/2"	3/4"	70	95	105	142
9/16" wheel bolts	7/8"	170	231		
5/8"	15/16"	170	231	210	285
5/8" wheel nuts	1-1/16"	240	325		
3/4"	1-1/16"* or 1-1/8"	250	339	375	509
7/8"	1-5/16"	350	475	600	814
1"	1-1/2"	450	610	880	1193
1-1/4"	1-7/8"	500	678		
1-1/2"	2-1/4"	570	773		
2"	3-1/8"	1200	1627		

*Nylon Lock Nut

3/8/12 TILLAGE

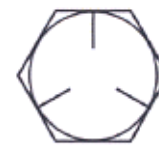
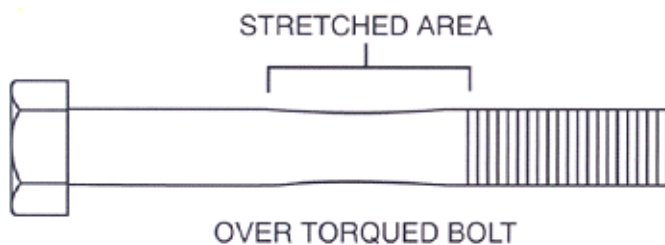

SAE
GRADE 5



SAE
GRADE 8

BRING OWNER REGISTER INFORMATION LOCATED AT THE BEGINNING OF THIS MANUAL WHEN ORDERING PARTS (SERIAL NUMBER IS LOCATED AT FRONT OF DISK BY HITCH PIECE).

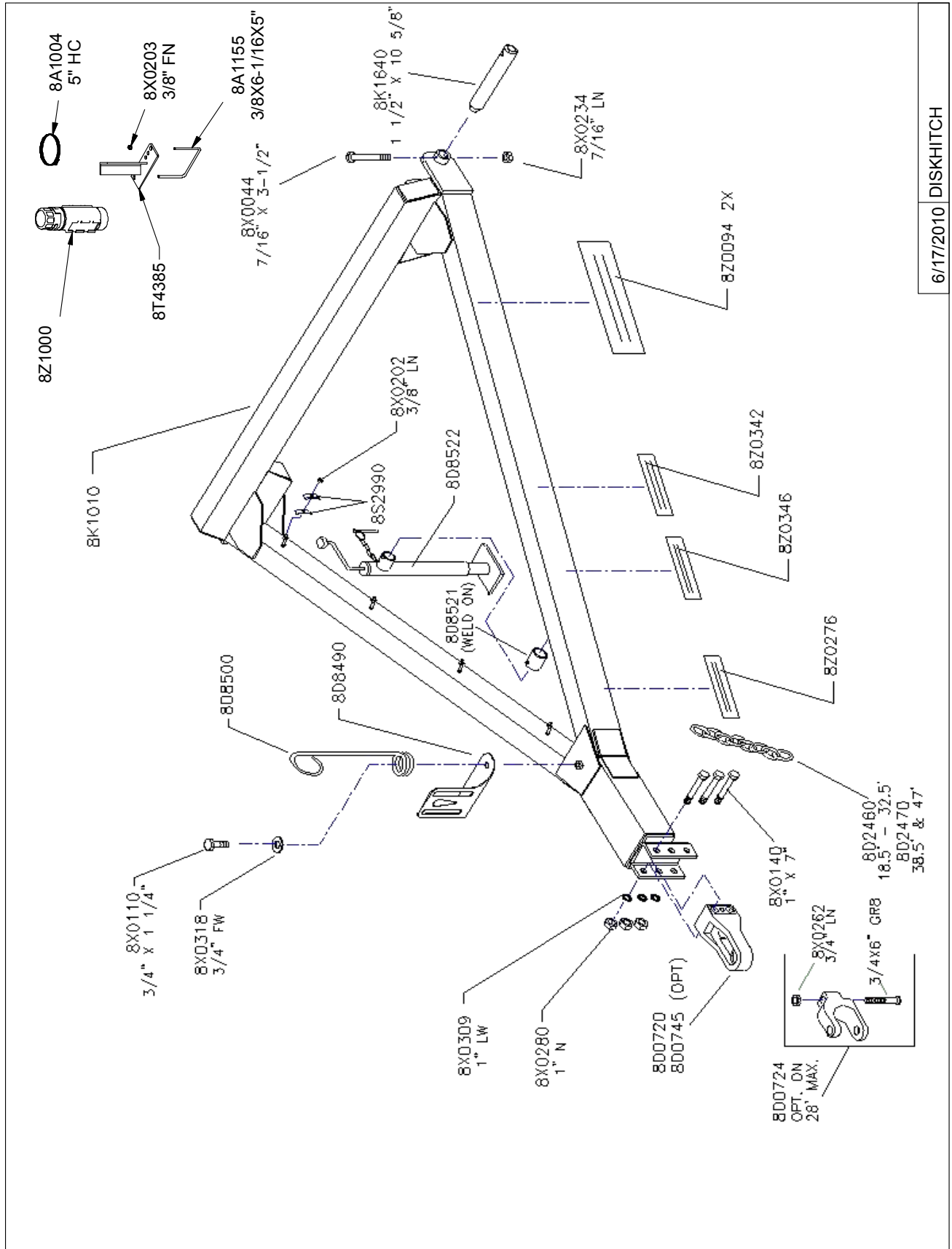

6/17/2010 DISKHITCH

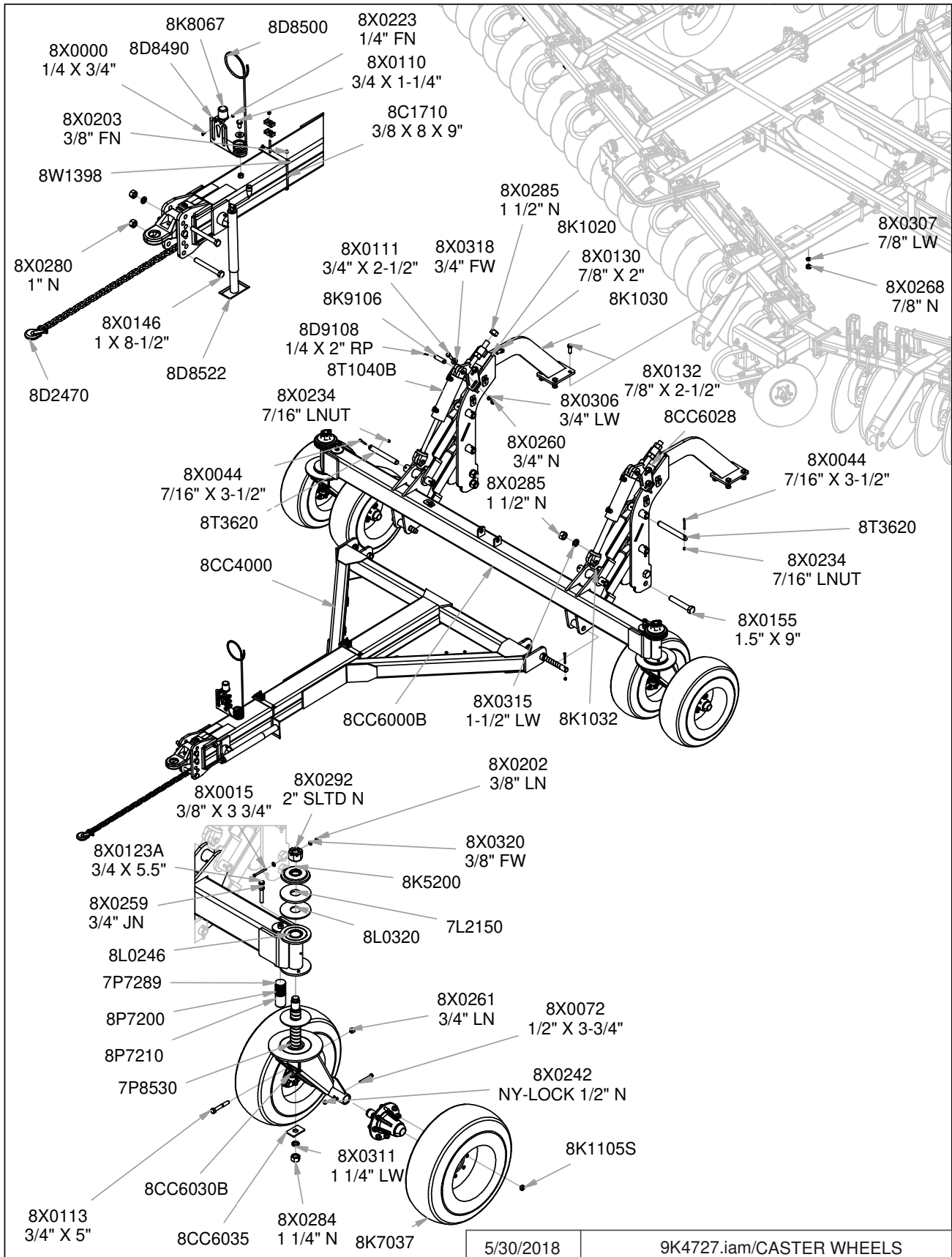

5/30/2018

9K4727.iam/CASTER WHEELS

MAIN FRAME 18.5' - 32.5' UNITS

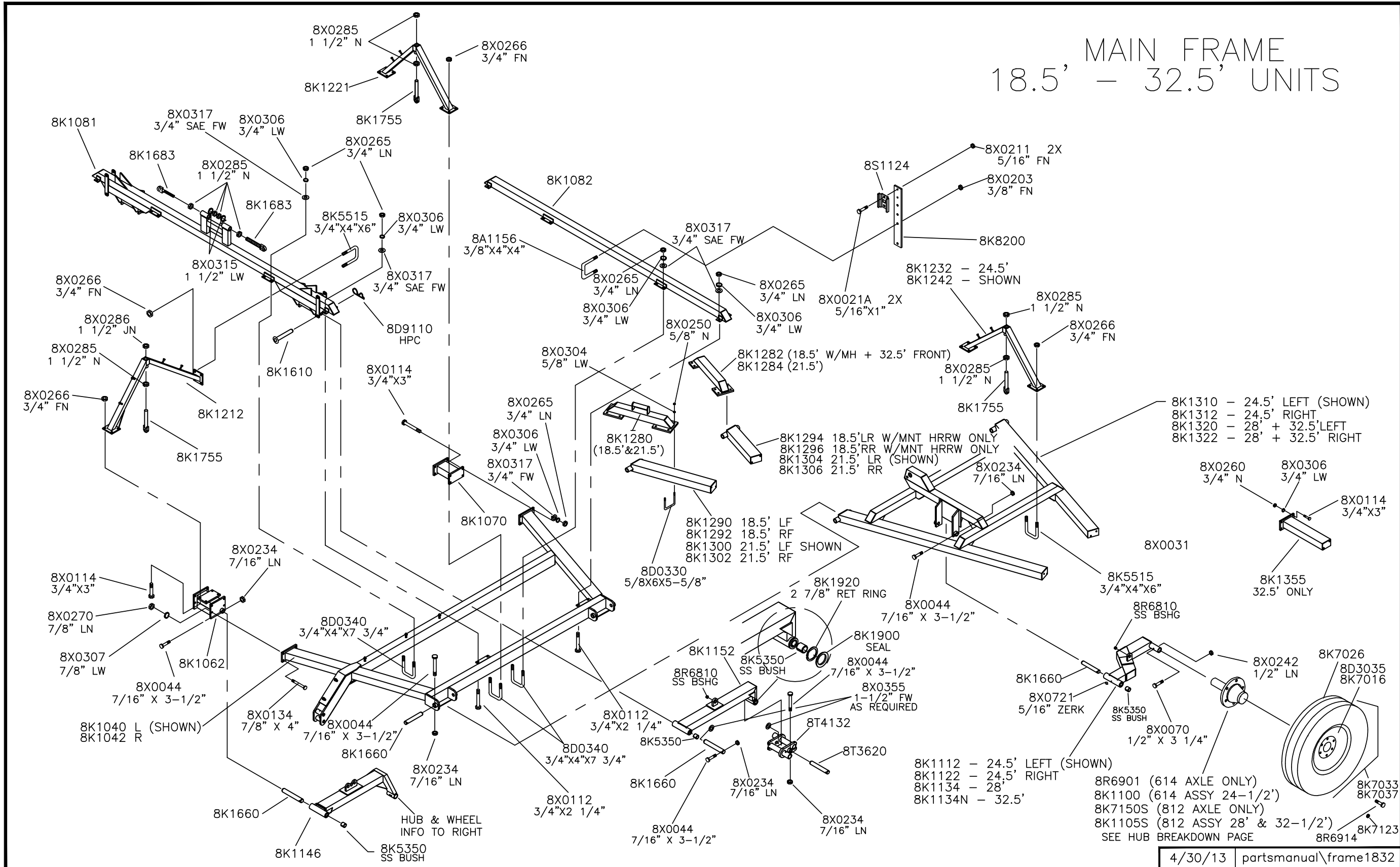

HYDRAULIC SYSTEM 18.5' & 21.5' UNITS

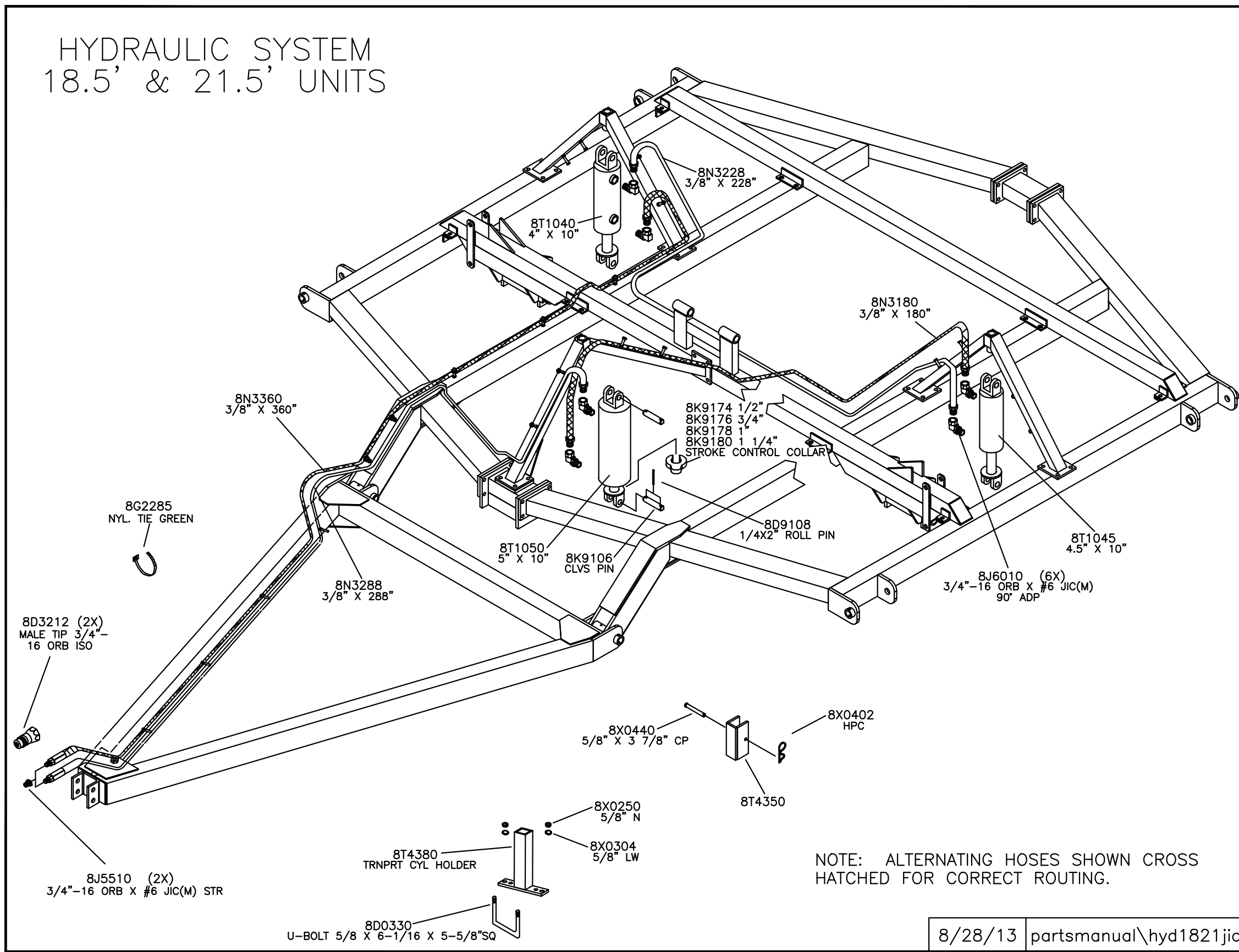

8/28/13 partsmanual\hyd1821jic

HYDRAULIC SYSTEM 24.5' THROUGH 32.5' UNITS

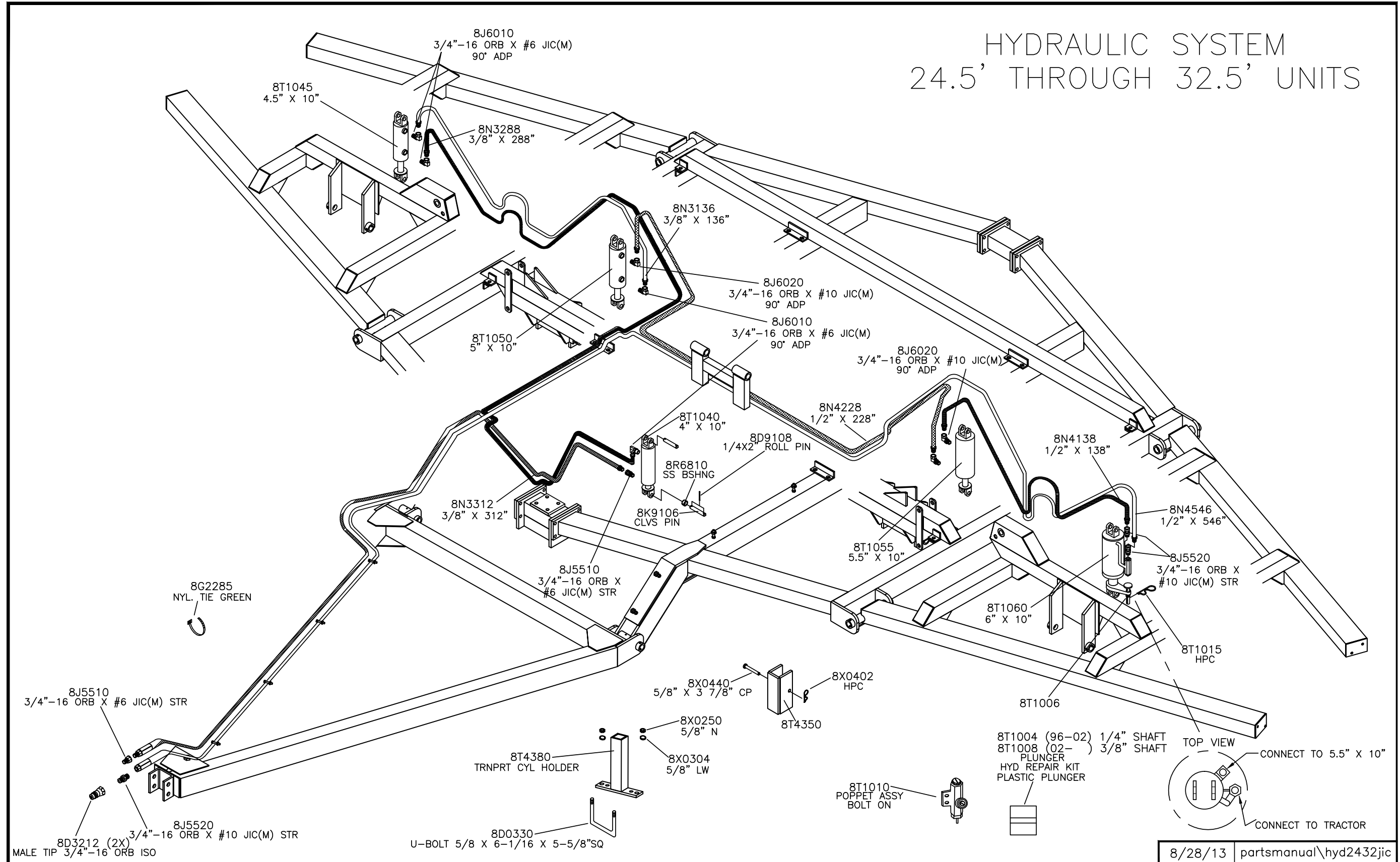

8/28/13 partsmanual\hyd2432jic

HYDRAULIC SYSTEM WING FOLD 24.5' THROUGH 32.5' UNITS

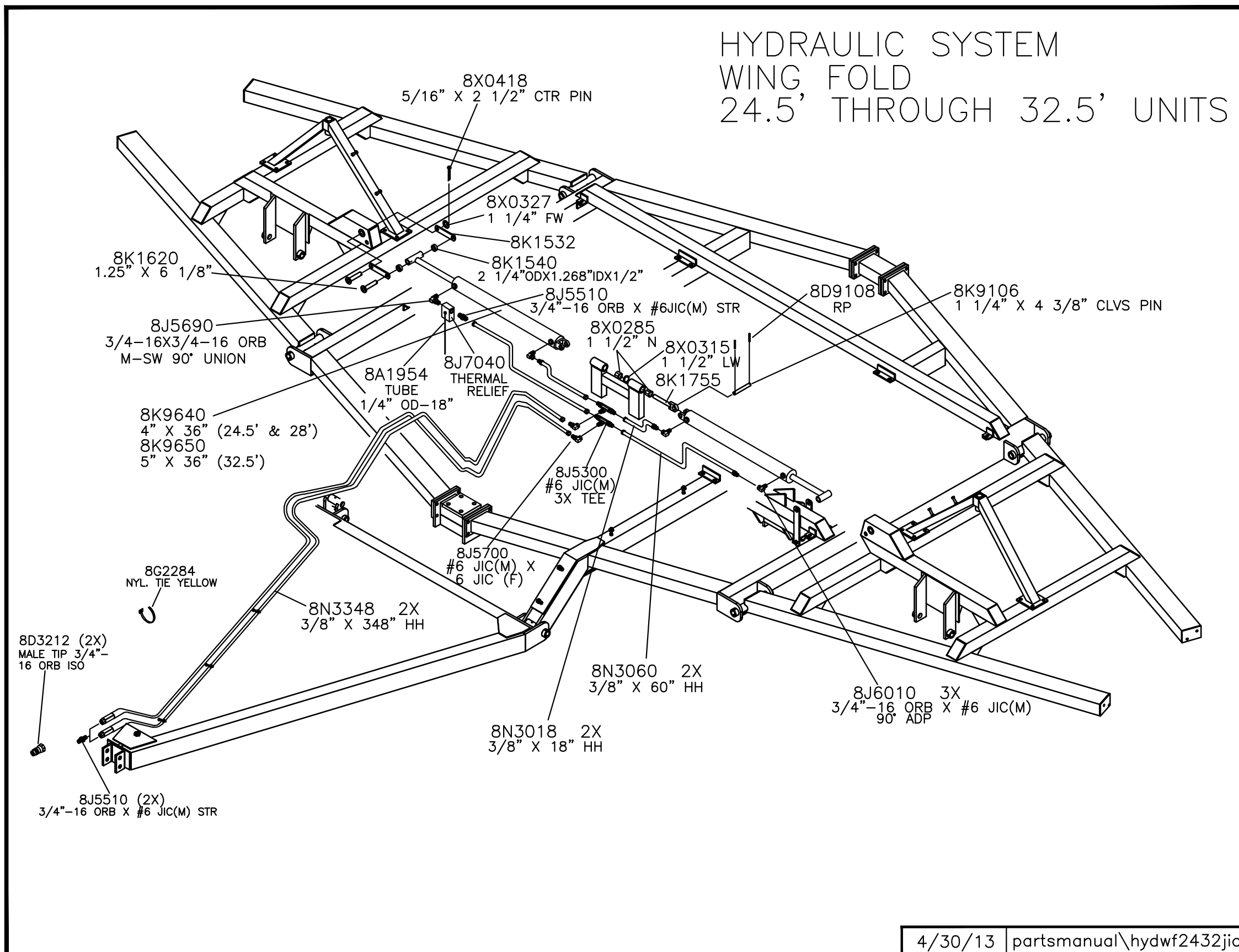

4/30/13 partsmanual\hydwf2432jic

MAIN FRAME 38.5' & 44.5' UNITS

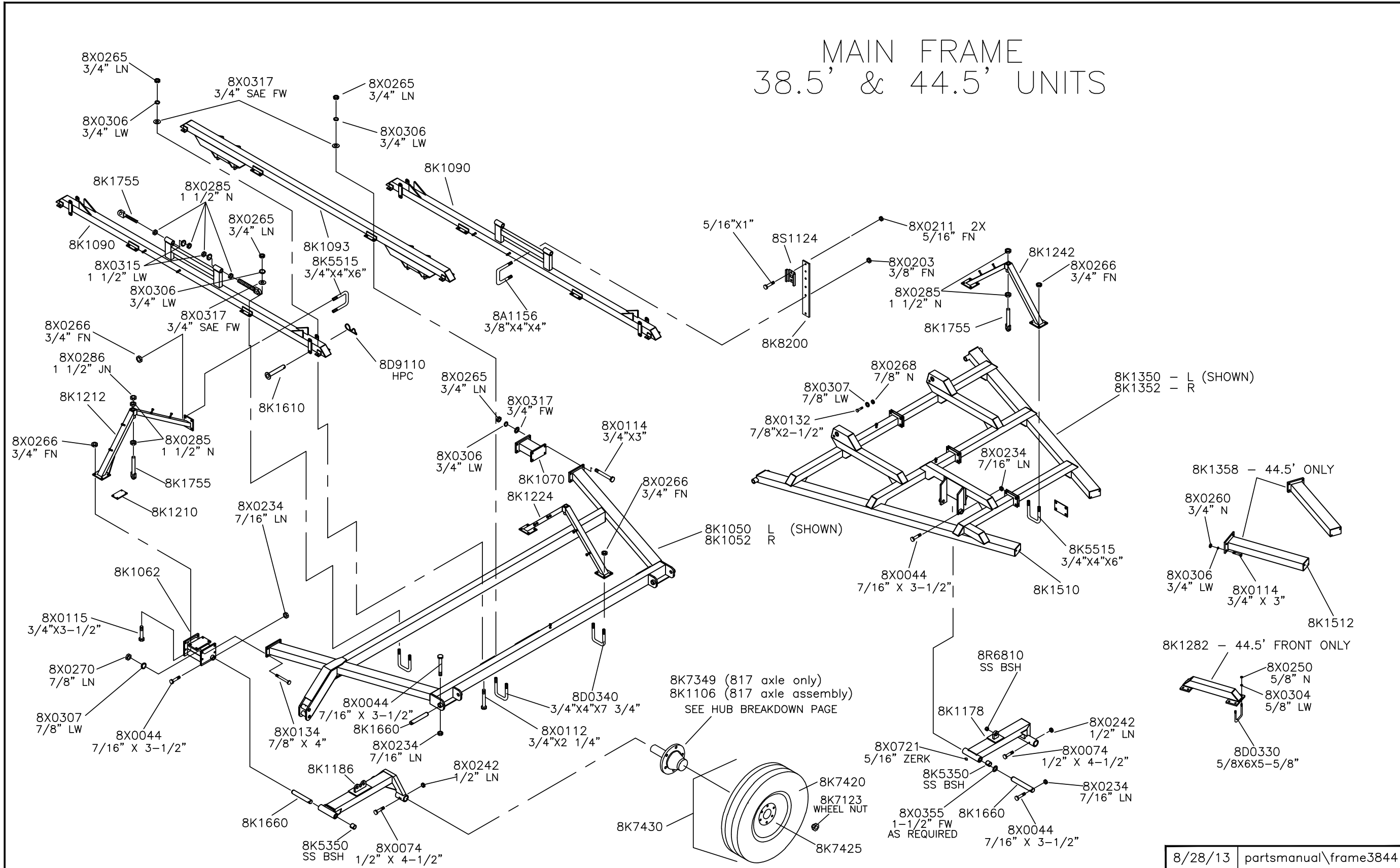

MAIN FRAME - 47' UNITS

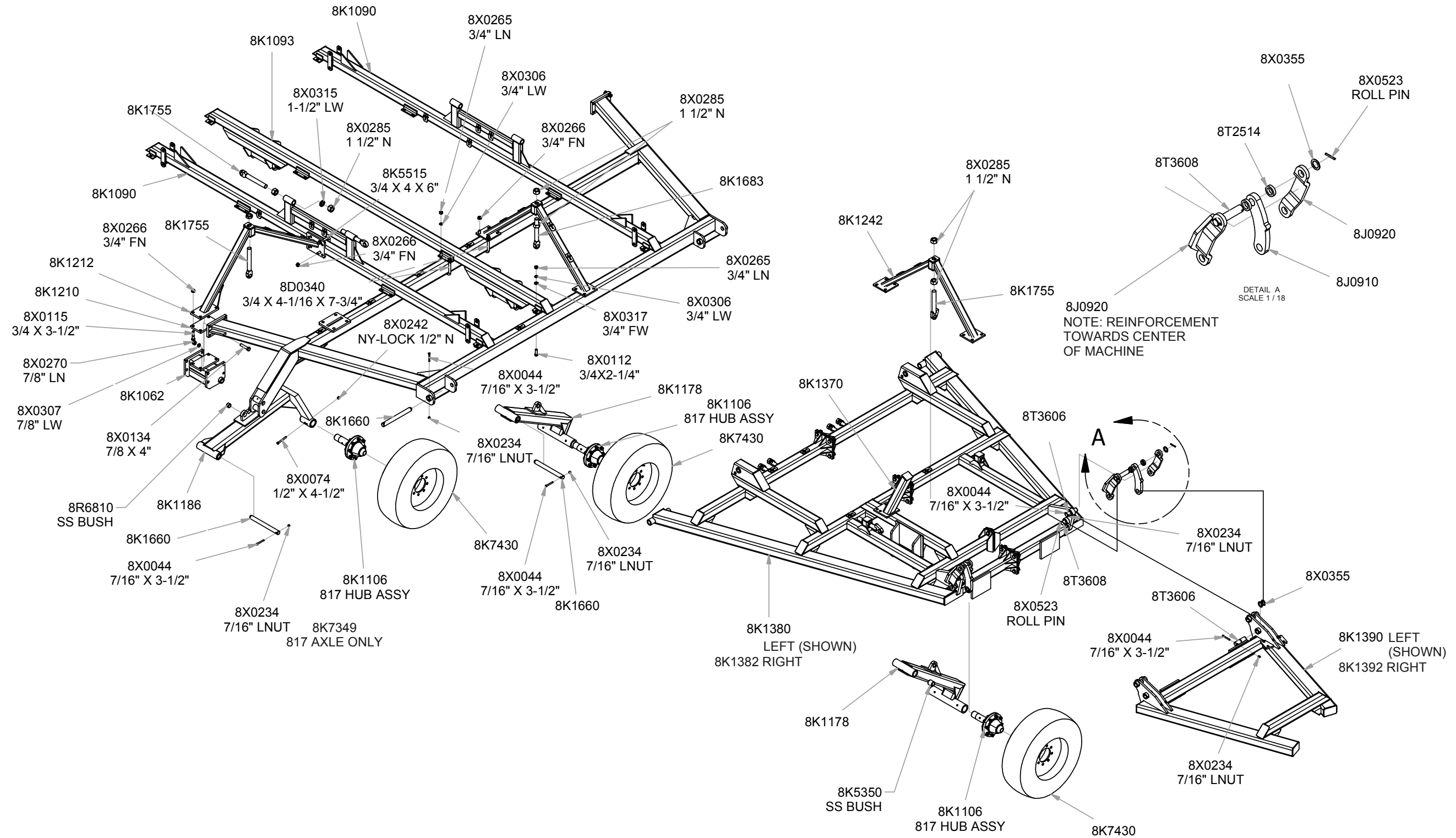

8/28/2013

9K4727.iam/47' DISK MAIN FRAME

HYDRAULIC SYSTEM 38.5', 44.5' AND 47' UNITS

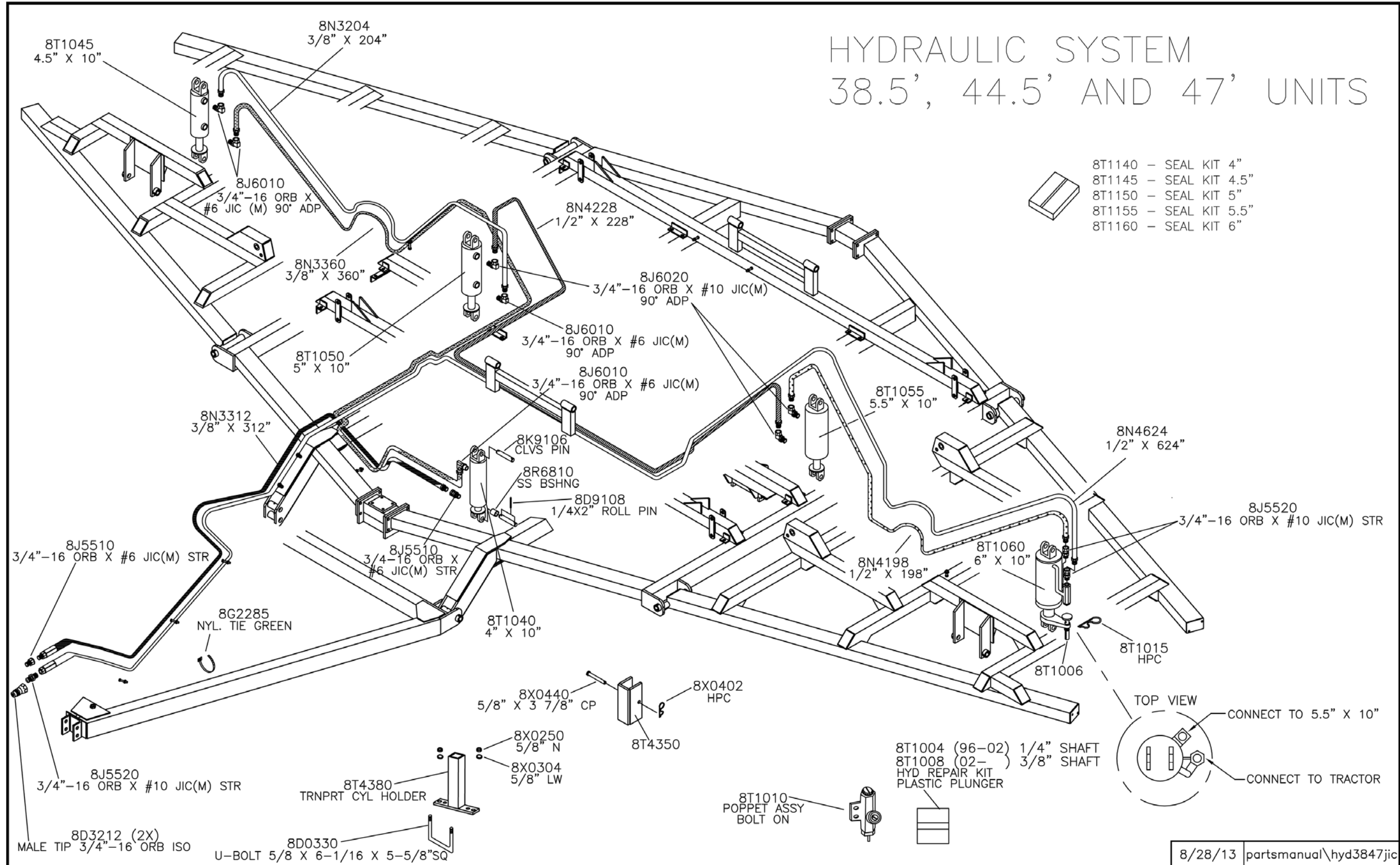

8/28/13 partsmanual\hyd3847jic

HYDRAULIC SYSTEM WING FOLD 38.5' AND 44.5' UNITS

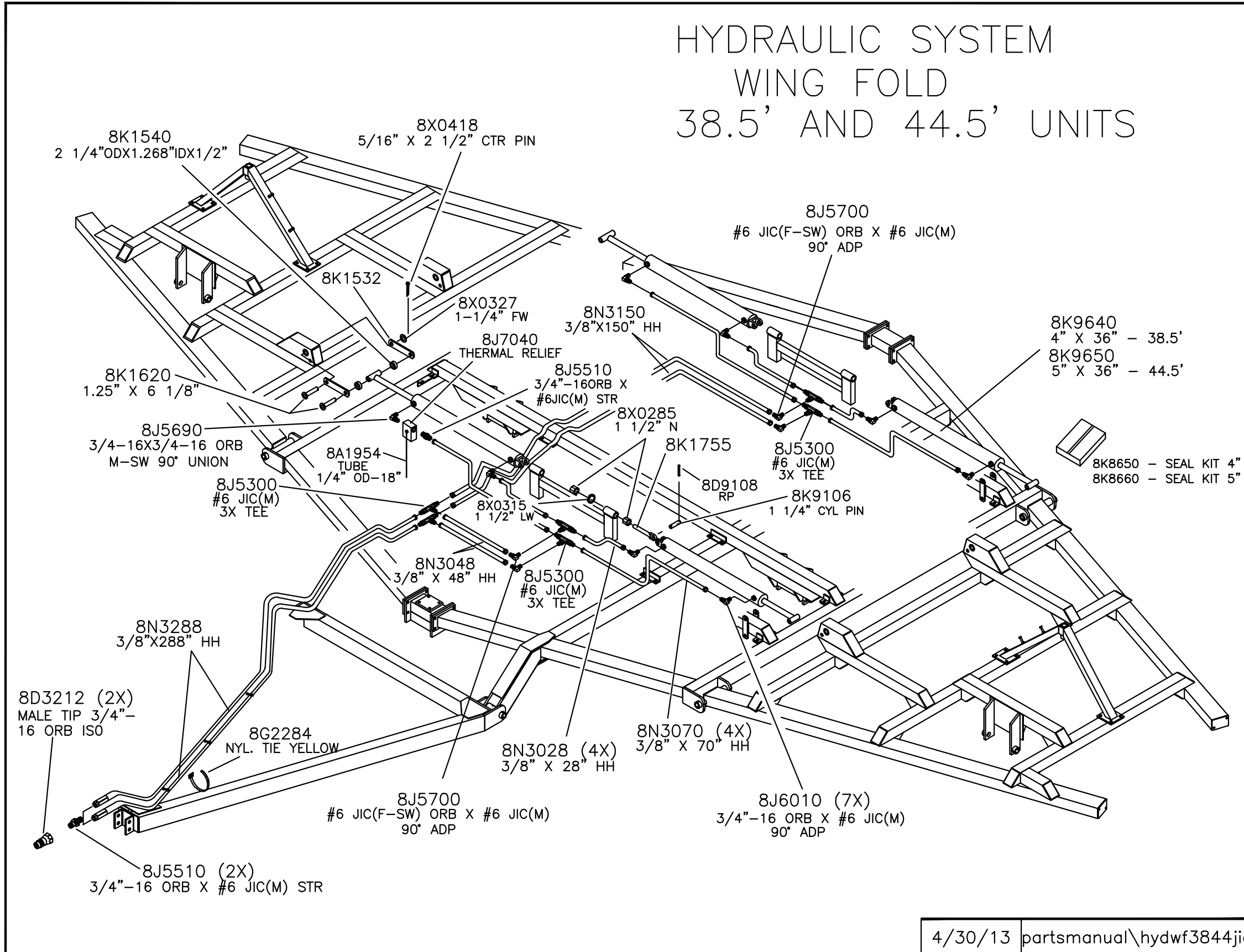

4/30/13 partsmanual\hydwwf3844jic

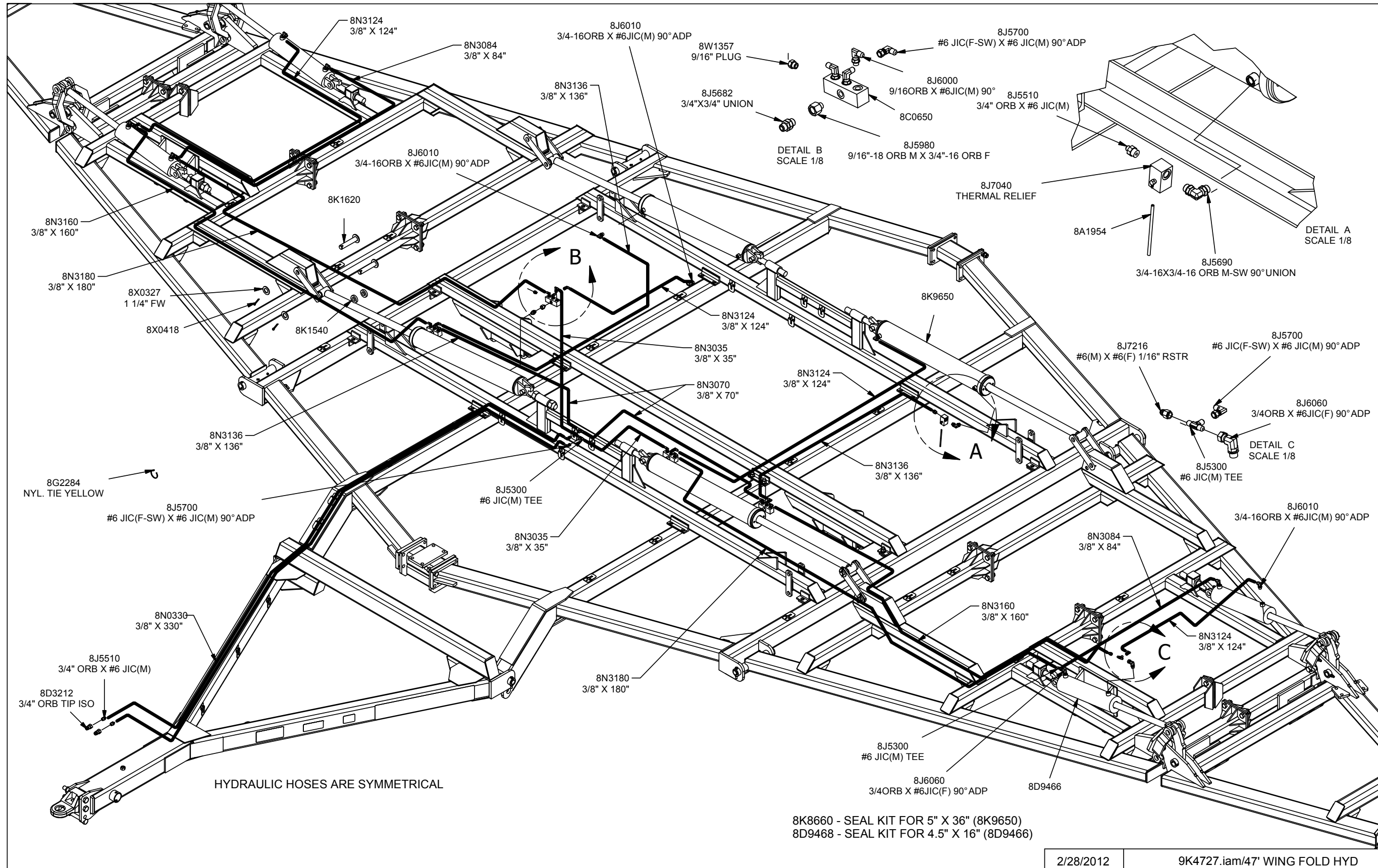

2/28/2012

9K4727.iam/47' WING FOLD HYD

GANG ASSEMBLY

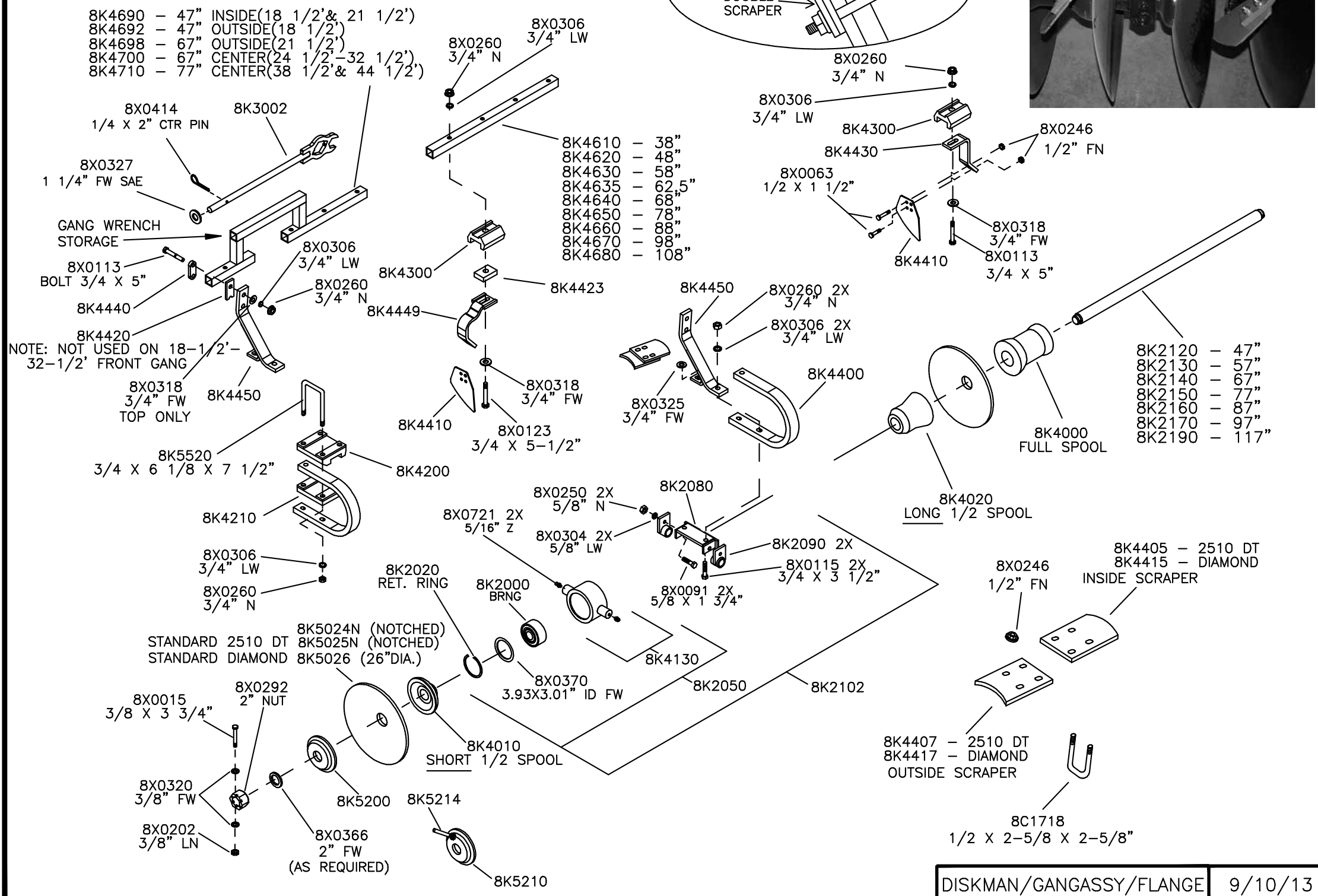

DISKMAN/GANGASSY/FLANGE 9/10/13



Rear Center - Ahead of Rear Gangs

**MOUNTING INSTRUCTIONS
FOR DISK COULTER
ASSEMBLY (8K6890)**

Mount coulters assembly with bracket and hardware provided. Adjust coulters penetration by loosening the 1/2" diameter retaining carriage bolts and sliding coulters assembly up or down to desired working depth.

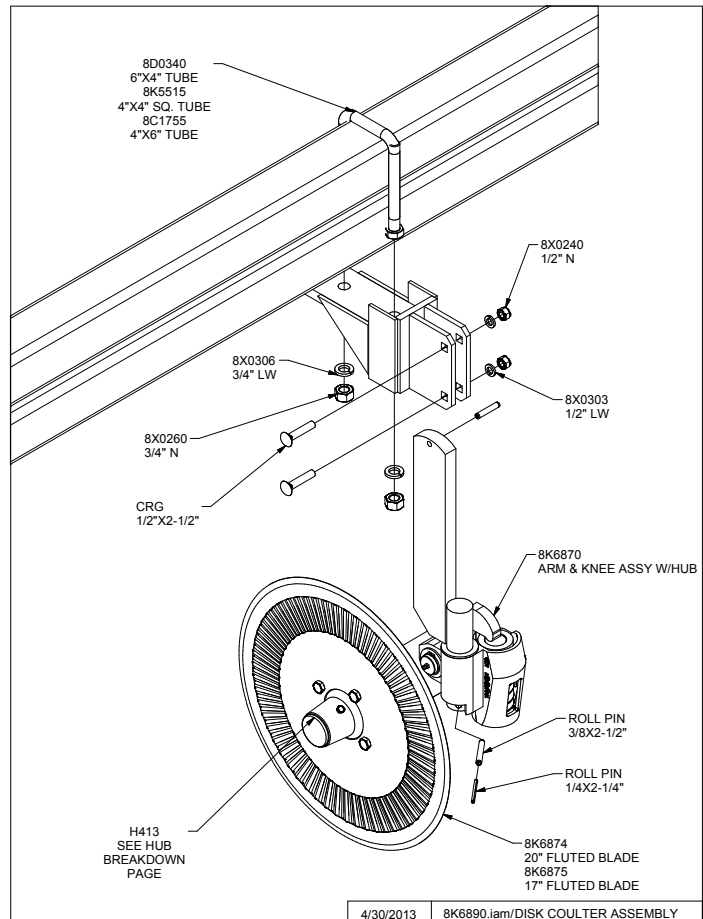

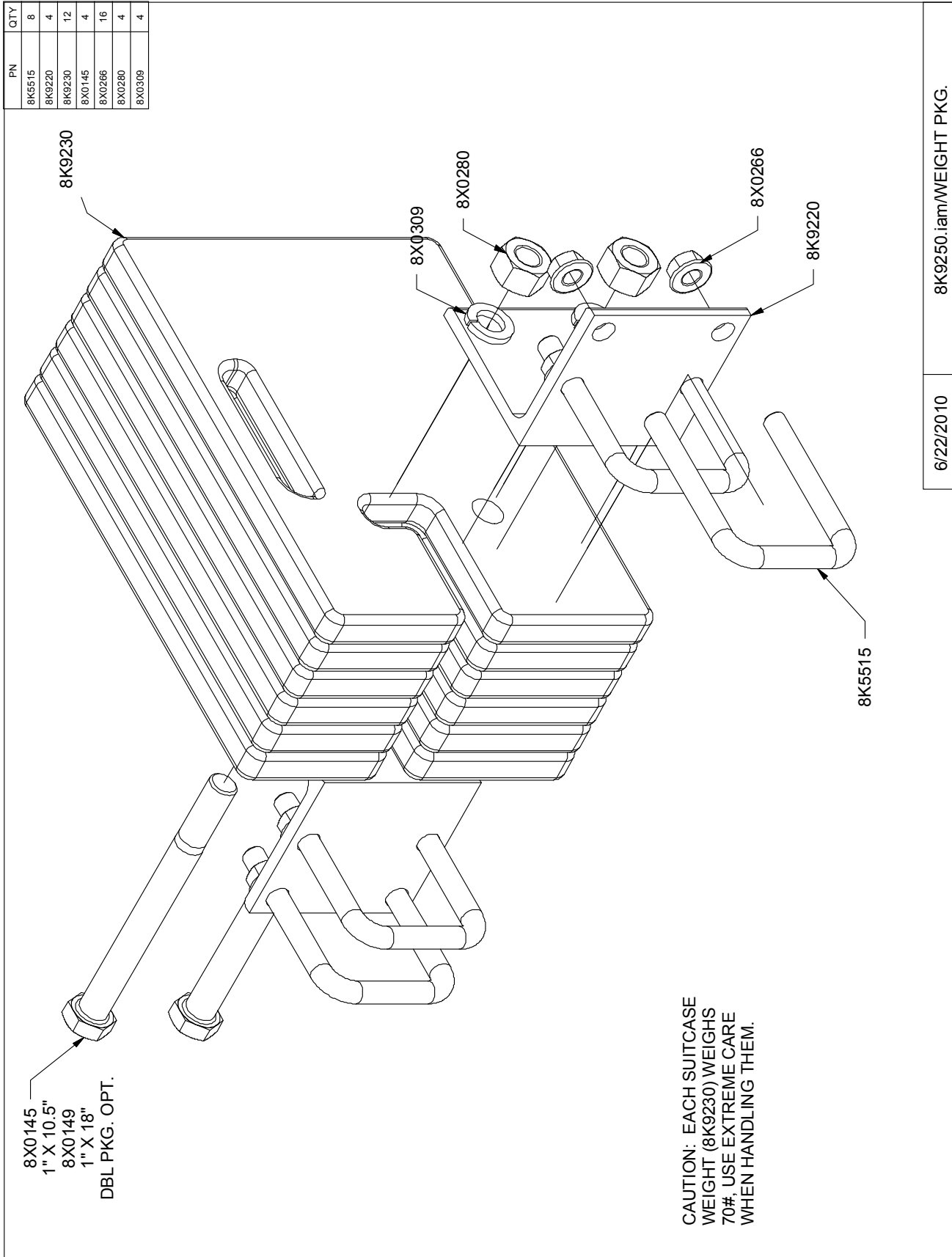

8K9250.iam/WEIGHT PKG.

6/22/2010

TRIP ASSEMBLY

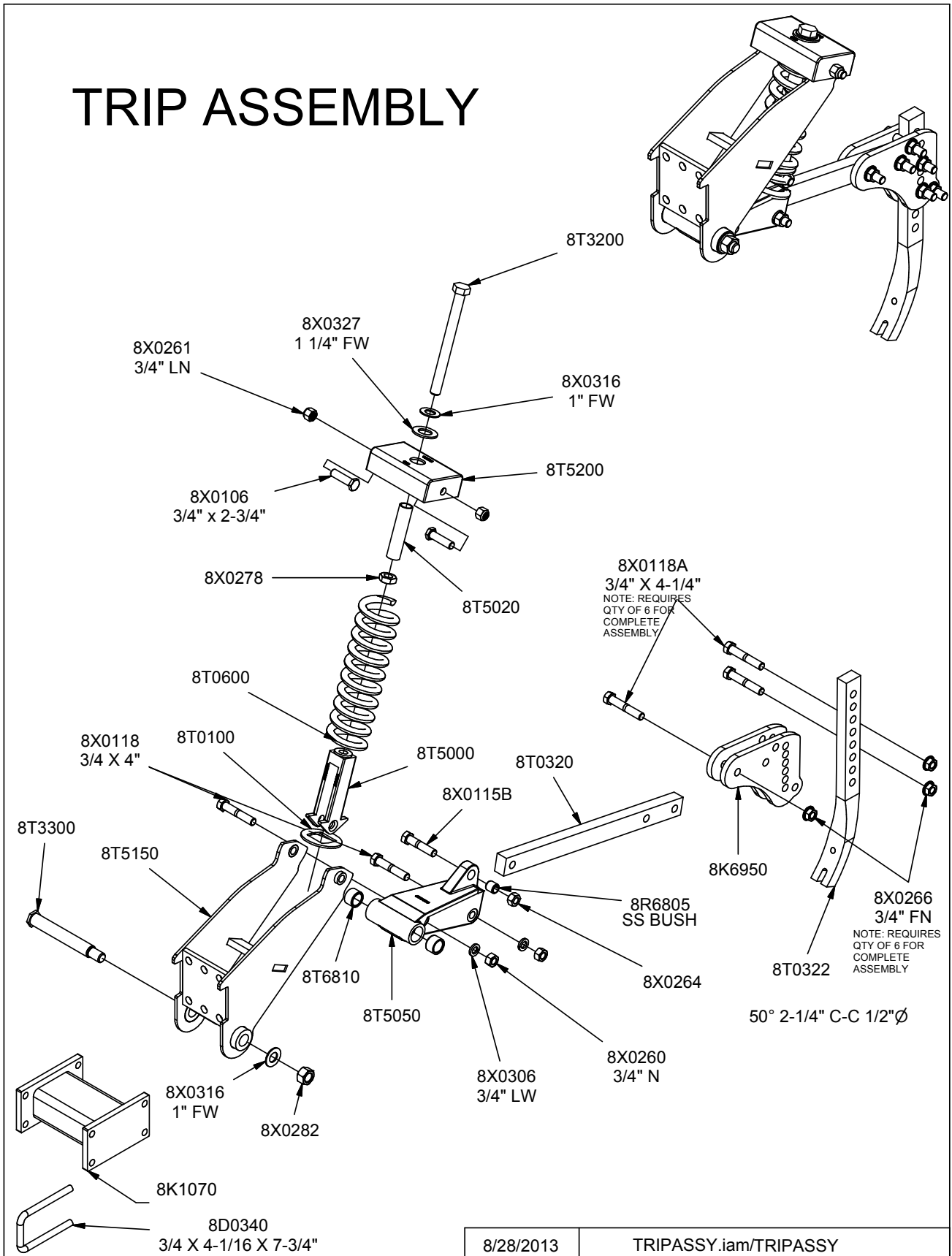

8/28/2013	TRIPASSY.iam/TRIPASSY
-----------	-----------------------

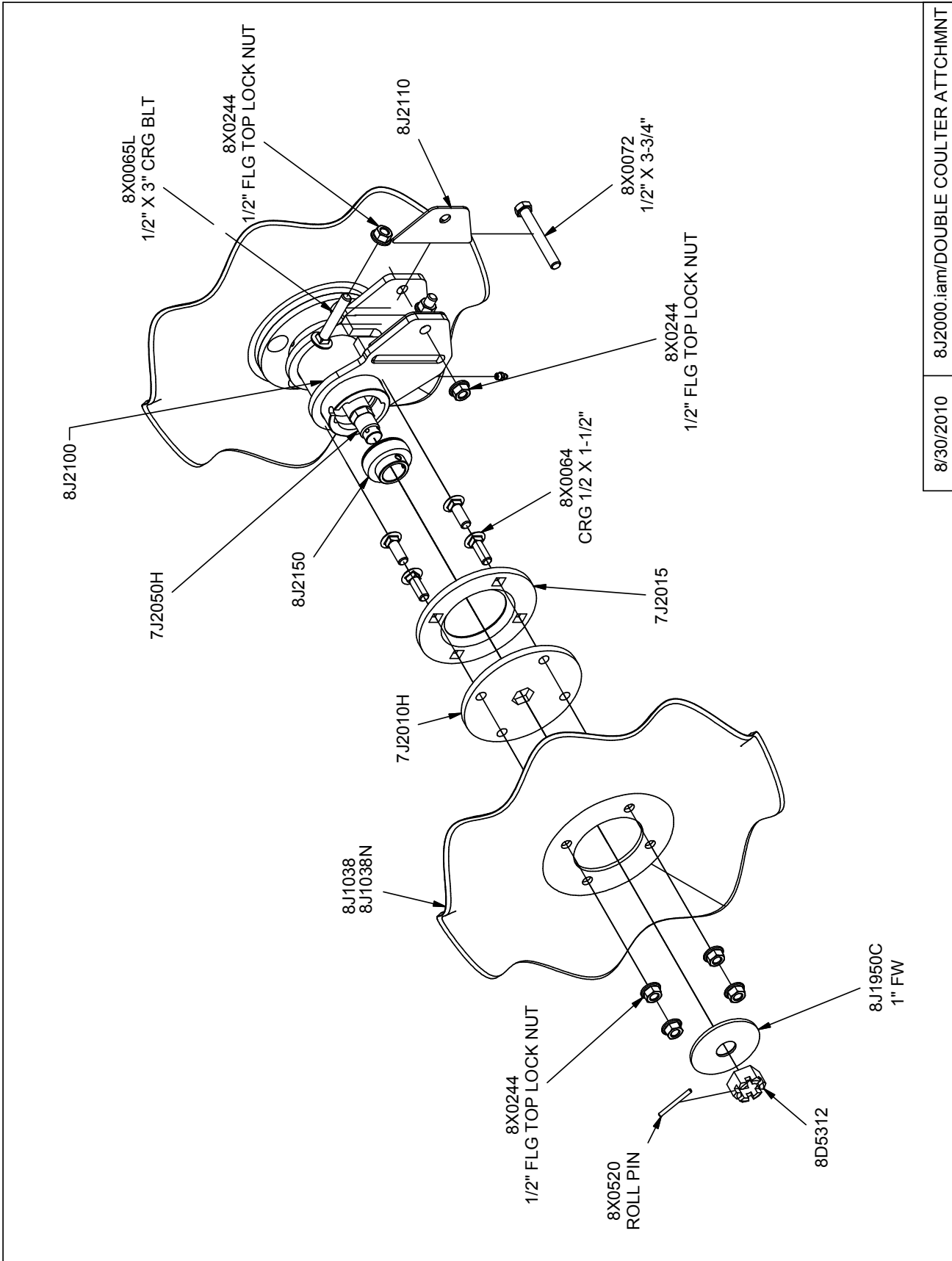

8/30/2010 8J2000.iam/DOUBLE COULTER ATTCHMNT

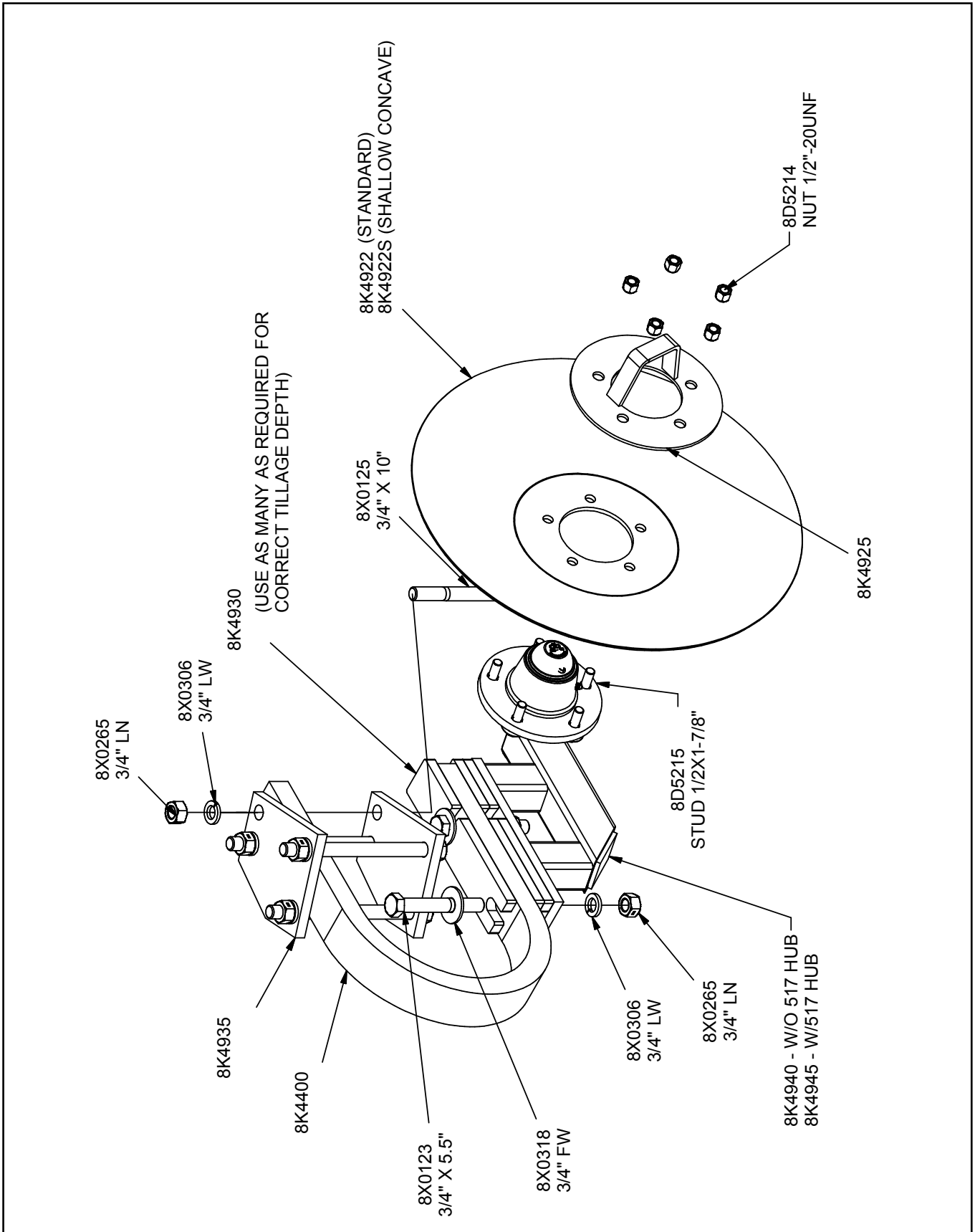

REAR COULTER GANG

(STANDARD ON DOMESTIC,
OPTIONAL ON EXPORT)

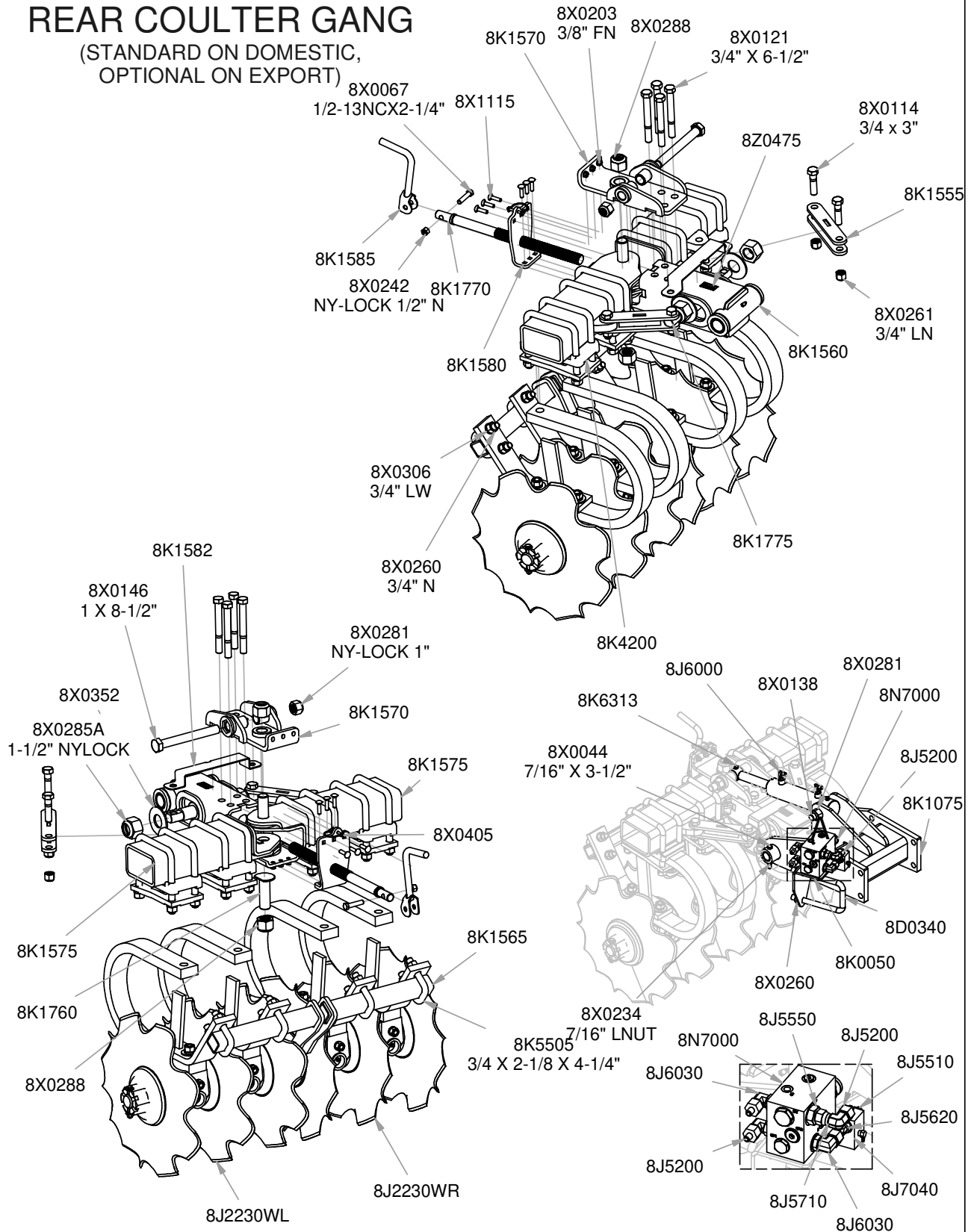

5/3/2018 8K6800.iam/UPGRADE KIT REAR ADJ GANG

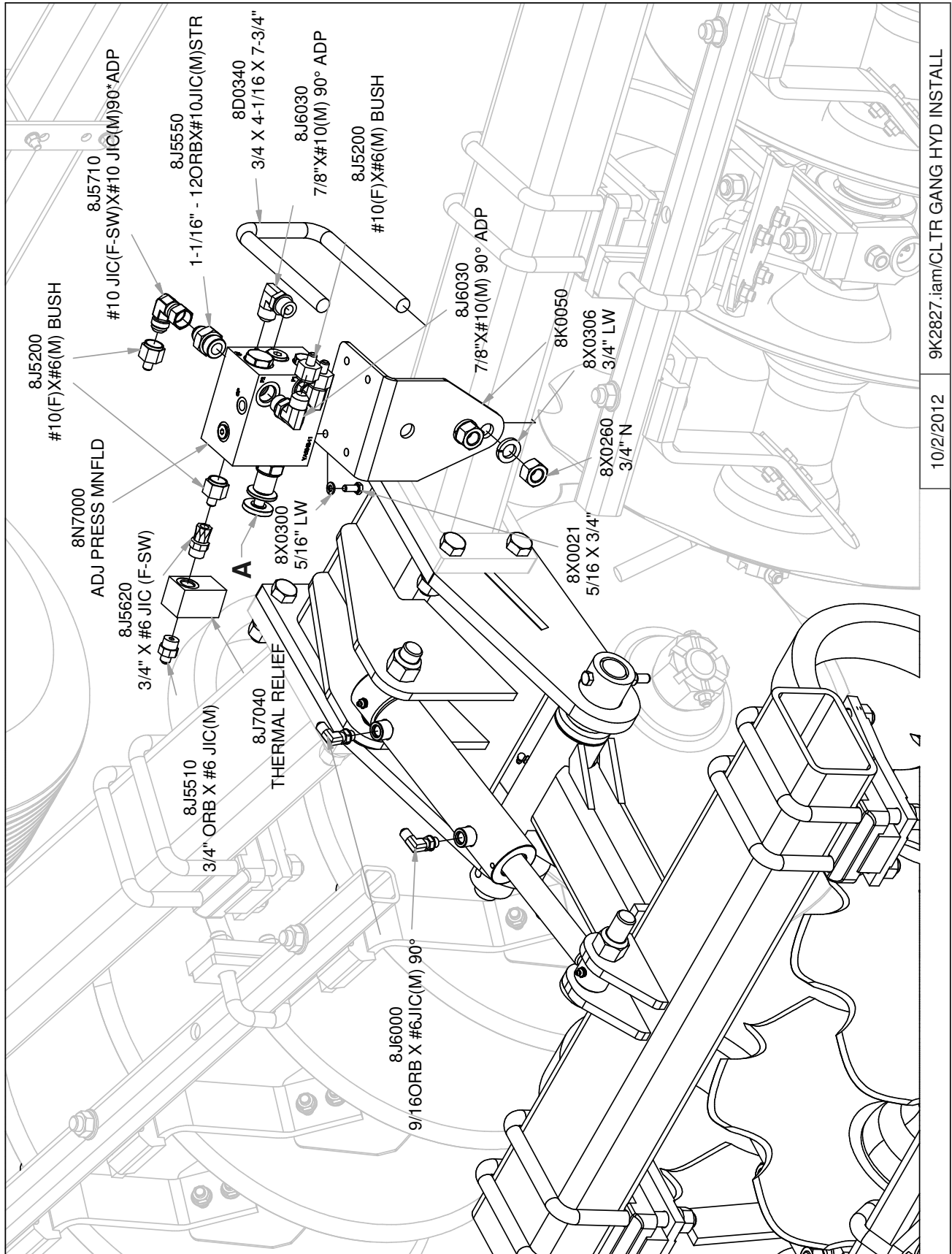

10/2/2012 9K2827.iam/CLTR GANG HYD INSTALL

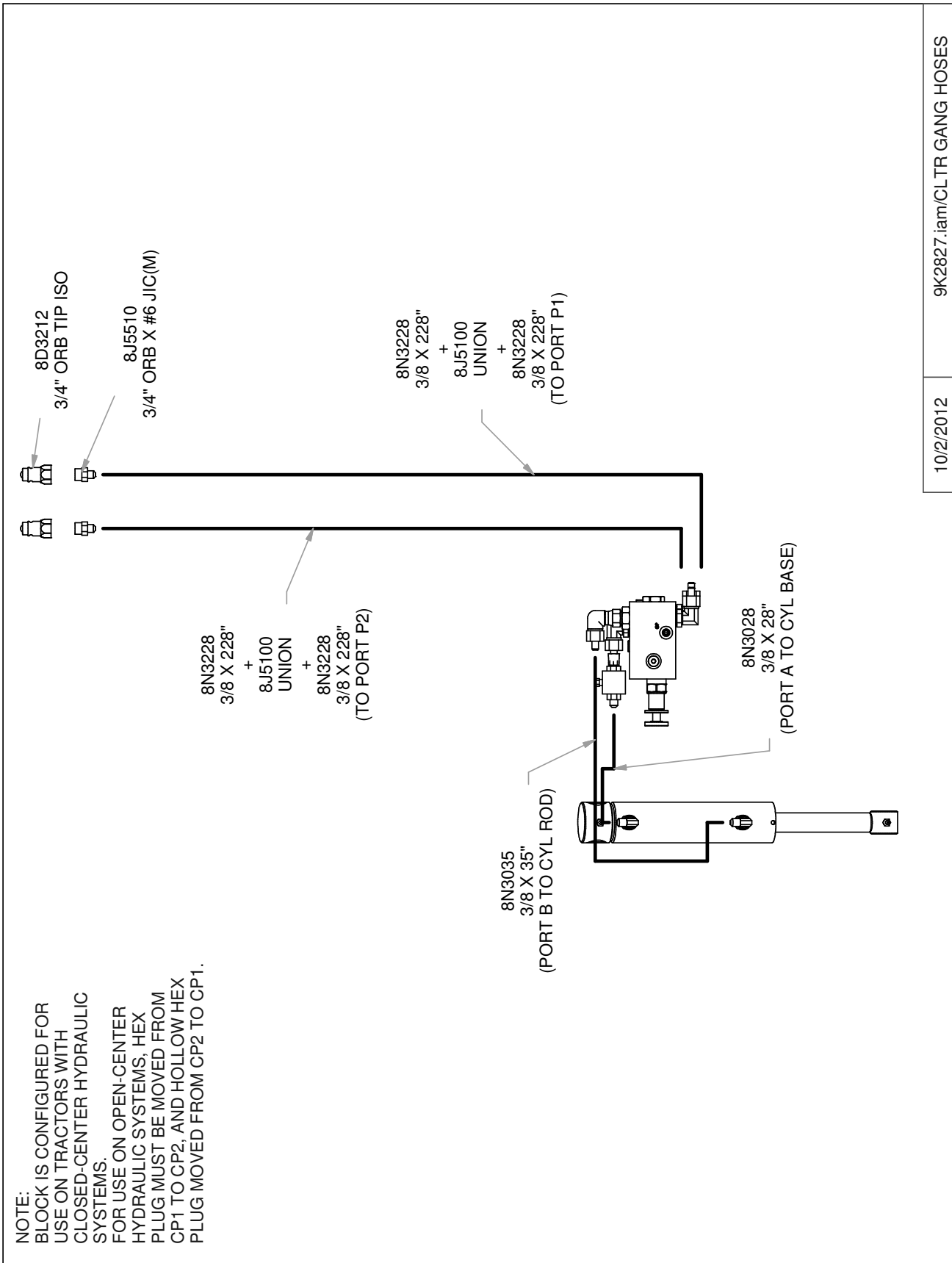

10/2/2012

9K2827.iam/CLTR GANG HOSES

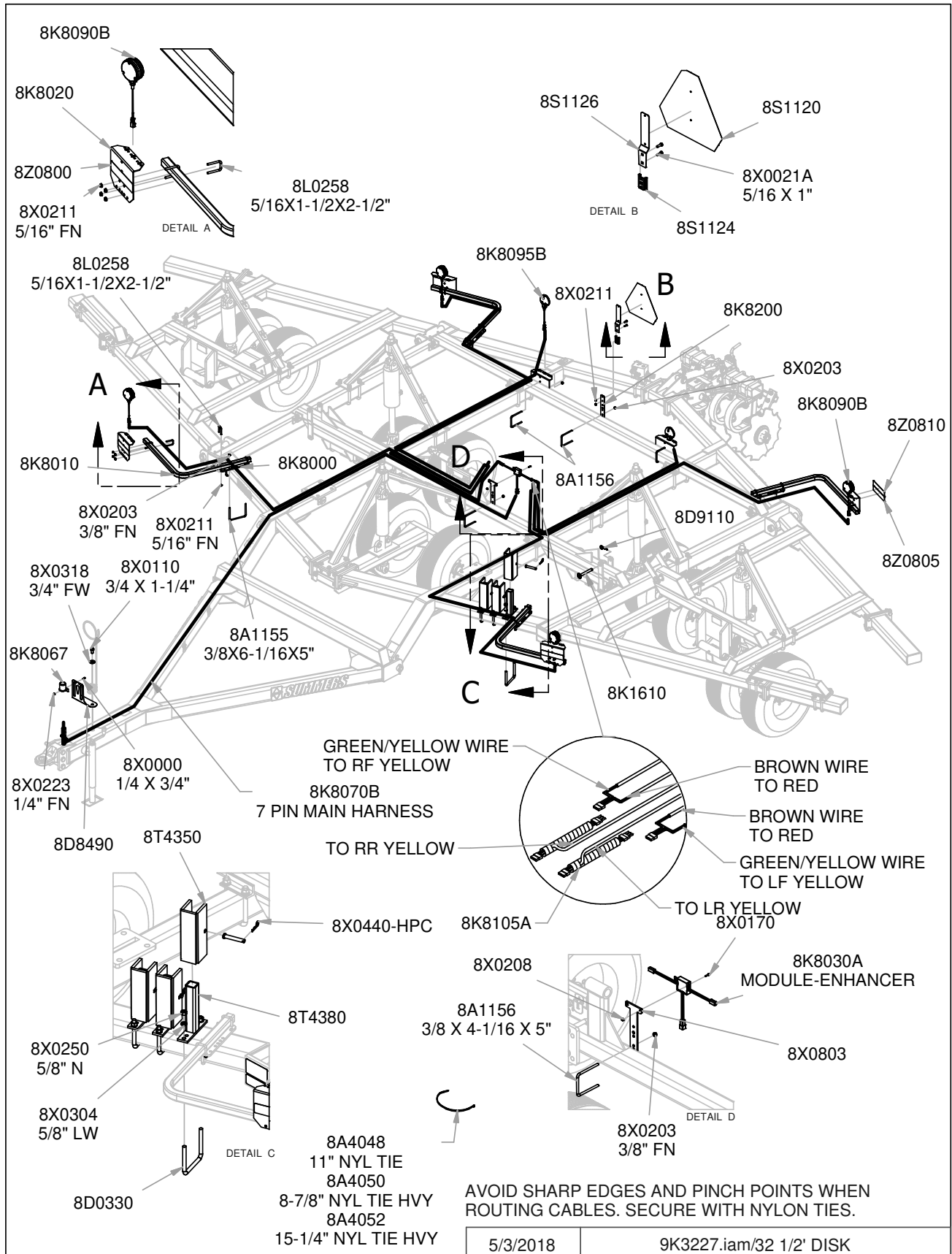

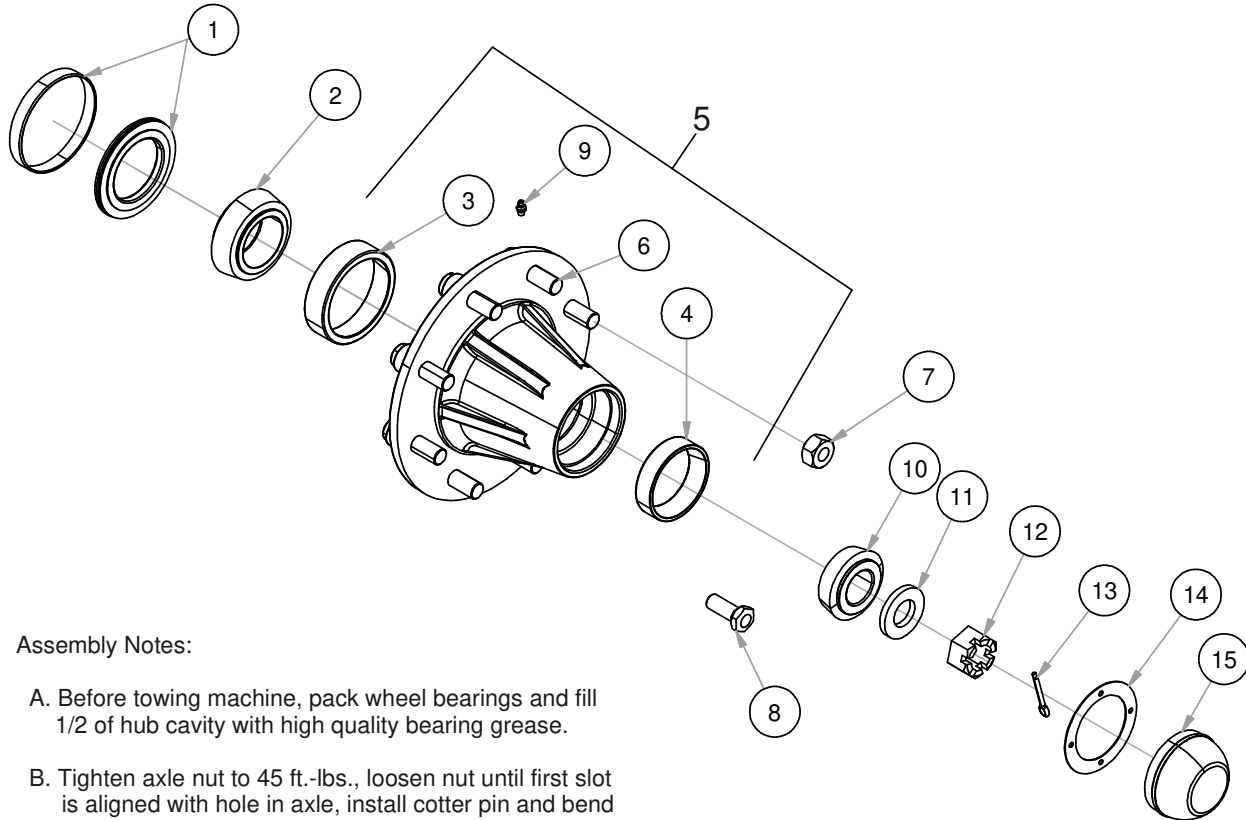

Assembly Notes:

- A. Before towing machine, pack wheel bearings and fill 1/2 of hub cavity with high quality bearing grease.
- B. Tighten axle nut to 45 ft.-lbs., loosen nut until first slot is aligned with hole in axle, install cotter pin and bend to retain.

HUB	1. SEAL	2. INNER BEARING	3. INNER RACE	4. OUTER RACE	5. HUB ASSY	6. WHEEL STUD	7. WHEEL NUT	8. WHEEL BOLT	9. HUB ZERK	10. OUTER BEARING	11. AXLE WASHER	12. AXLE NUT	13. COTTER PIN	14. HUB CAP GASKET	15. HUB CAP	16. HUB CAP BOLT
H211	8G8220	8G8217	8G8230	8G8230	8G8211	N/A	N/A	8D5114	8X0708	8G8217	8D5119	8D5112	8X0410	N/A	8G8212	N/A
	SE10	L44643	8L44610	L44610	HDA211			WB10	1/4-28NF	L44643	3/4" LD.	3/4"-16	3/16XT		DC11	
H517	8D5234	8D5217	8D5332	8D5336	8D5210	8D5215	8D5214	N/A	8X0708	8D5117	8S5219	8D5212	8X0415	N/A	8D5212	N/A
	8D5236	LM48548	LM48510	LM67010	H517	WB16	1/2-20UNF		1/4-28NF	LM67048	7/8" LD.	7/8"-14	3/16X1-1/2"		DC13	
H611	8D5221	8D5317	8D5334	8D5336	8D5311-09	N/A	N/A	8D5114	8X0708	8D5117	8D5319	8D5312	8X0415	N/A	8D5212	N/A
	SE13	LM29749	LM29710	LM67010	H611			WB10-09	8R6914	1/4-28NF	LM67048	1" LD.	1"-14		3/16X1-1/2"	DC13
H614	8R6922**	8R6917	8R6925	8D5332	8R6911	N/A	N/A	8R6914	8X0708	8D5217	8D5319	8D5312	8X0415	N/A	8R6912	N/A
	SEE GBI INSTRUCTIONS	LM603049	LM603011	LM48510	H614			WB12	1/4-28NF	LM48548	1" LD.	1"-14	3/16X1-1/2"		DC15	
HD812	8K7127***	8K7117	8K7130	8K7132	8K7111	8K7115-9/16**	8K7116-9/16**	N/A	8X0708	8K7118	8D5319	8D5312	8X0415	N/A	8K7113	N/A
	8K7128***	LM3780	LM3720	LM2720	HD812	WB41	WB40		1/4-28NF	LM2790	1" LD.	1"-14	3/16X1-1/2"		DC17	
HD817	8K7344	8K7342	8K7346	8K7347	8K7340	8K7122-5/8"	8K7123-5/8"	N/A	8X0708	8K7343	8X0328	8D5314	8X0414	N/A	8K7341	N/A
	SE42	LM387AS	382A	LM50130	HD817	WB46	WB18		1/4-28NF	LM501349	1.312 LD.	1-1/4"-12	1/4X2"		DC26	
HD10 LT	8K7220	8K7217	8K7230	8K7232	8K7211	8K7215	8K7216	N/A	8X0708	8K7218	8X0328	8D5314	8X0414	8K7212	8K7212	8K7214
	SE48	39585	39520	453A	HD10-9	WB51	WB52		1/4-28NF	460	1.312 LD.	1-1/4"-12	1/4X2"	SE49	DC27	WB53
HD10 HVY	8K7221	8K7219	8K7231	8K7232	8K7210	8K7215	8K7216	N/A	8X0708	8K7218	8X0328	8D5314	8X0414	8K7212	8K7212	8K7214
	SE67	33275	33462	453A	HD10-11	WB51	WB52		1/4-28NF	460	1.312 LD.	1-1/4"-12	1/4X2"	SE49	DC27	WB53
HD1020	8K7320	8K7317	8K7330	8K7332	8K7209	8K7215	8K7216	N/A	8X0708	8K7318	8X0366	8D5318	8X0418	8K7312	8K7312	8K7214
	SE55	HM218248	HM218210	HM212010	HDA1020	WB51	WB52		1/4-28NF	HM212049	2.03" LD	2"-12WB65	5/16 X 2-1/2"	SE59	DC28	WB53

**Pre 2000
 **GBI(Not Shown), 8R6921 Triple Lip (Shown)
 ***Pre 2006 8K7120 (SE17)

614 HUB W/GBGI SEAL

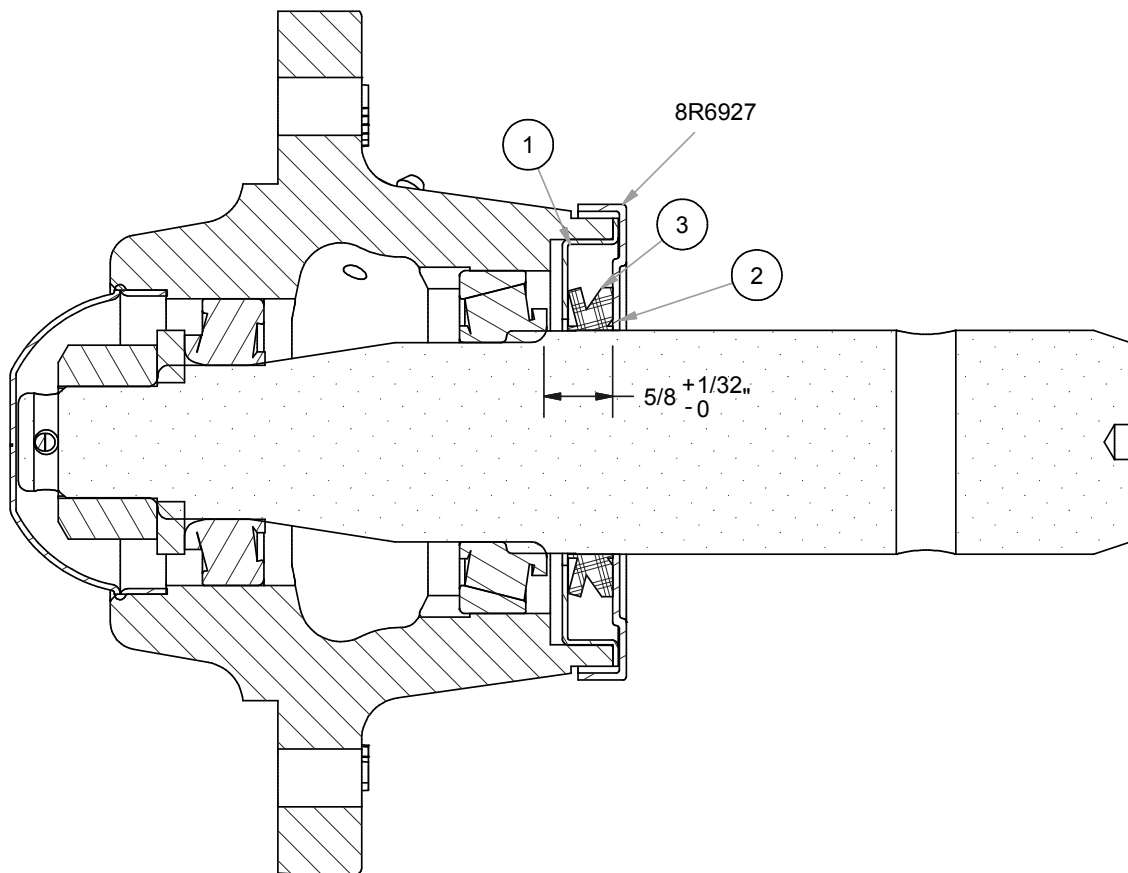

INSTALLATION INSTRUCTIONS FOR 8R6922 SEAL ASSEMBLY (3 PIECE-GBGI) FOR H614 HUB:

SEAL SUPPORT (2 - 8R6927)

PRESS SEAL SUPPORT (2) ONTO SPINDLE 5/8" (+1/32", -0") PAST INNER BEARING RETAINING SHOULDER.

- A. IF SEAL SUPPORT IS NOT PRESSED ON SPINDLE FAR ENOUGH THE SEAL SUPPORT WILL RUB ON HUB.
- B. IF SEAL SUPPORT IS PRESSED TOO FAR ONTO SPINDLE IT WILL CAUSE IMPROPER CONTACT BETWEEN RUBBER SEAL (3) AND INNER SEAL SUPPORT (1) RESULTING IN BEARING CONTAMINATION AND FAILURE.

NOTE: APPLY THIN LAYER OF GREASE TO COUNTERFACE (1) SURFACE AT TIME OF SEAL INSTALLATION.

SEAL COUNTERFACE (1 - 8R6924)

PRESS SEAL COUNTERFACE INTO HUB UNTIL SHOULDER CONTACTS HUB.

V-SEAL (3 - 8R6923 (A-994))

STRETCH V-SEAL OVER SEAL SUPPORT UNTIL ITS BACK IS SEATED AGAINST THE BACK SHOULDER OF SEAL SUPPORT AND LIES SMOOTH ALL AROUND.

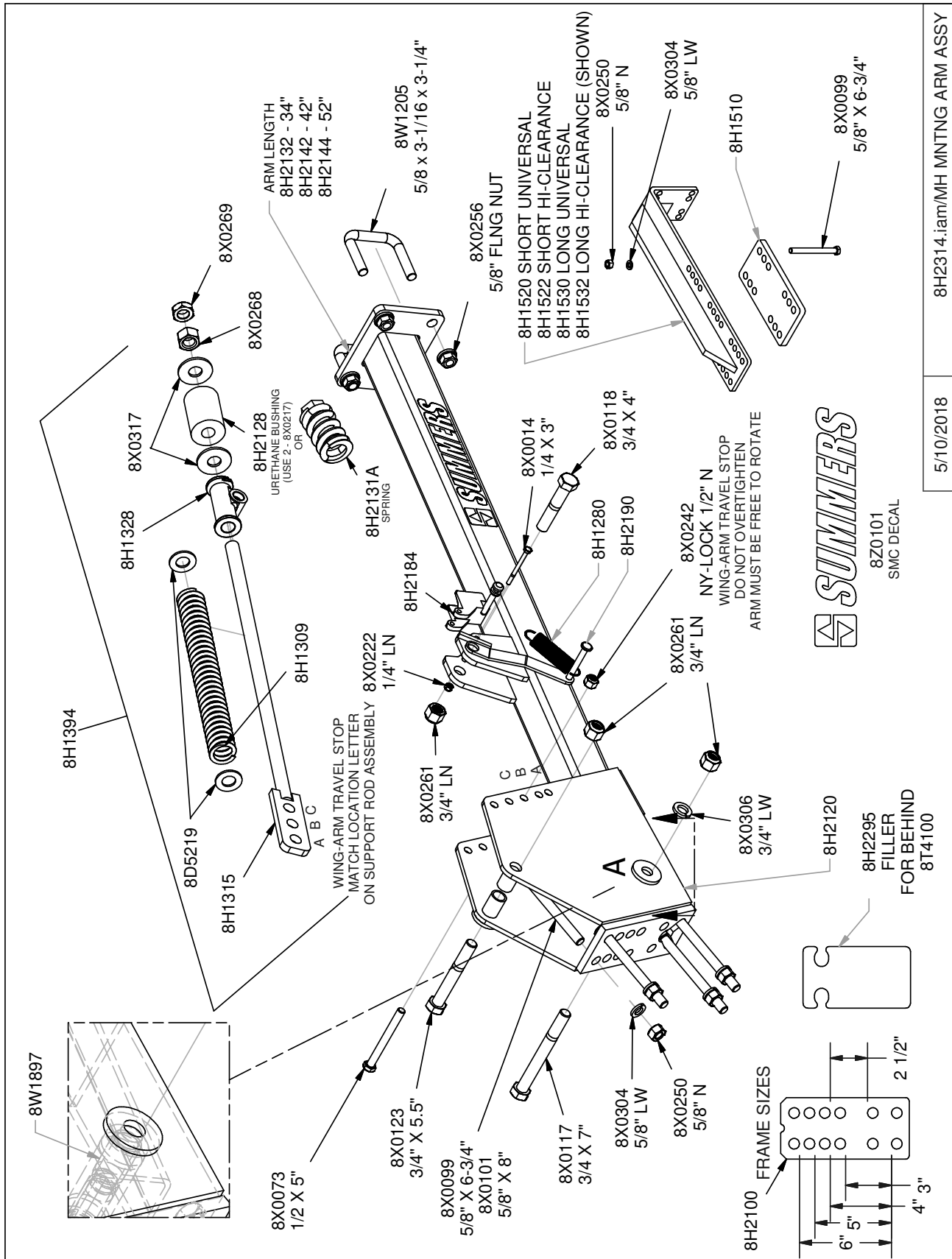

5/10/2018 8H2314.iam/MH MNTNG ARM ASSY

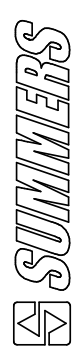

8Z0101 SMC DECAL

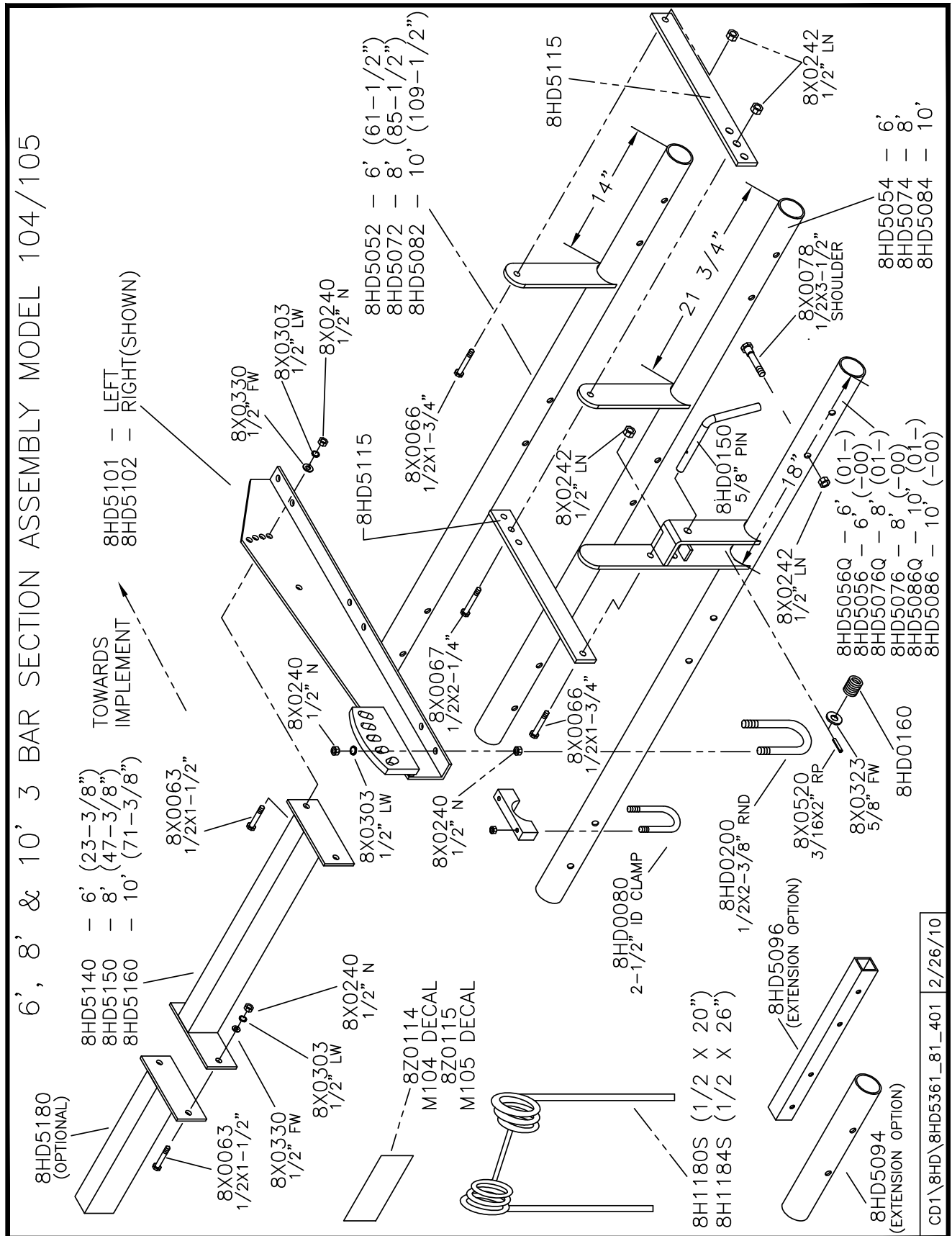

CD1\8HD\8HD5361_81_401 | 2/26/10

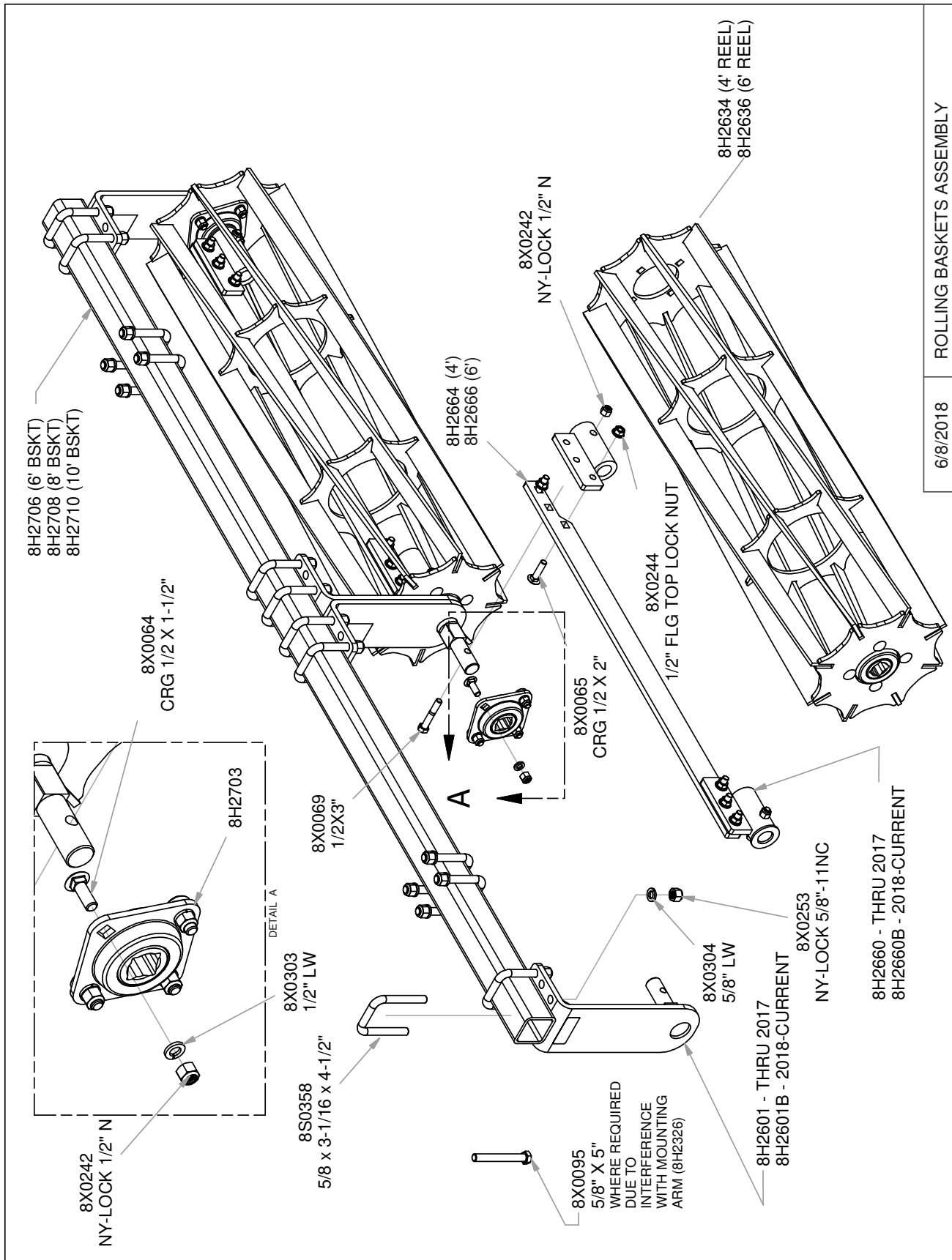

6/8/2018 ROLLING BASKETS ASSEMBLY

HYDRAULIC ROLLING BASKET

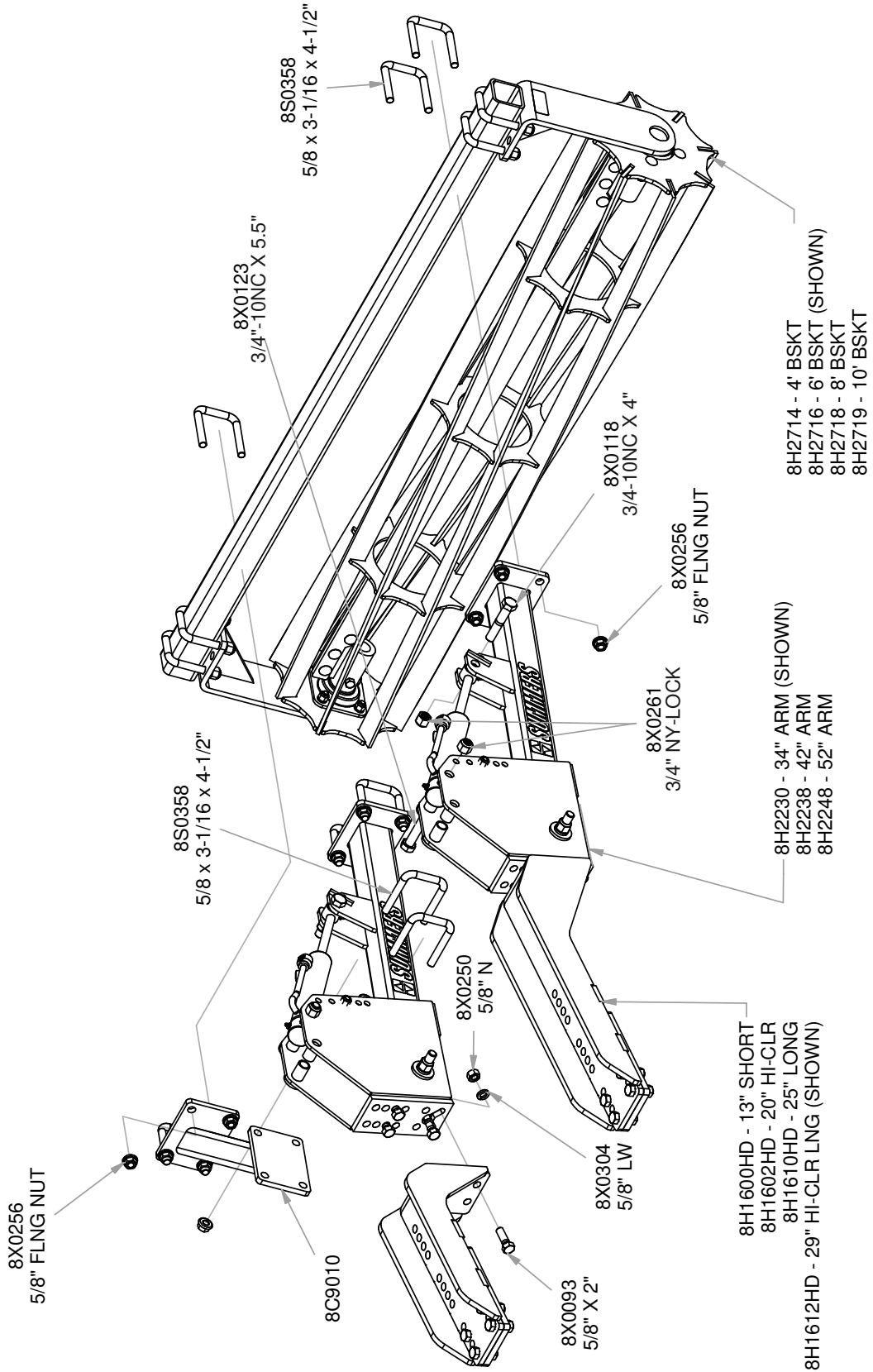

HYD_RLLNG_BSKTS.iam/

6/7/2018

INSTALLATION AND OPERATION INSTRUCTIONS FOR 8K1850

HUBODOMETER W/ HOUSING FOR SUMMERS DIAMOND DISK AND 2510 DT

Attach HUB ODOMETER to gang nut as shown in photos with 3/8" x 4-1/2" bolt, flat washers and lock nut. To prevent loosening, rotate gang to insure that bracket is on center and spot weld at locations shown.

Position Hubodometer on inside of rear center gang. DO NOT LOCATE HUBODOMETER BENEATH IMPLEMENT WING HINGE OR AT WIDEST POINT OF MACHINE. Hub Odometer will be damaged if installed in these locations.

The Hub Odometer is calibrated at 359 revolutions per acre. Refer to chart below for conversion for your implement.



MACHINE	CONVERSION FACTOR
Diamond Disk Width	Multiply by ___ for Acres Covered
18 1/2'	1.04
21 1/2'	1.22
24 1/2'	1.37
28'	1.58
32 1/2'	1.82
38 1/2'	2.16
44 1/2'	2.49
47'	2.63
2510 DT Width	
18 1/2'	1.00
21 1/2'	1.17
24 1/2'	1.32
28'	1.52
32 1/2'	1.75
38 1/2'	2.08
44 1/2'	2.39
47'	2.53

CD1/8K/8K1850

Stock Code	Description	Stock Code	Description
8A1004	CLAMP HOSE 5" #72	8K1052	CENTER FRAME 16' RGHT 84-
8A1155	U-BOLT 3/8 X 6-1/16 X 5" SQ	8K1062	SPLICE TUBE FRNT W/BLT PL84-
8A1156	U-BOLT 3/8 X 4-1/16 X 5" SQ	8K1075	SPLICE TUBE REAR W/PIVOT 11-
8A1954	TUBING GAGE LINE 1/4"OD PER FT	8K1081	CROSSTUBE 18.5-32.5 FRNT 98-
8A4048	NYLON TIE .18 X 11"	8K1082	CROSSTUBE 18.5-32.5 REAR 84-
8A4050	NYLON TIE .30 X 8-7/8"	8K1090	CROSSTUBE 38.5-47 FRNT/RR 84-
8A4052	NYLON TIE .30 X 15.25"	8K1093	CROSSTUBE 38.5-47 MIDDLE 98-
8A4054	NYLON TIE .30 X 24" BLK	8K1100	HUB&AXLE ASSY 614(GBGI-2"RCVR)
8C0650	MANIFOLD BLOCK ALUMINUM 5 PORT	8K1105S	HUB&AXLE ASSY HD812 (2"RCVR)
8C1718	U-BOLT 1/2 X 2-5/8 X 2-5/8" SQ	8K1106	HUB&AXLE ASSY HD817(2.5"RCVR)
8D0330	U-BOLT 5/8 X 6-1/16 X 5-5/8"SQ	8K1112	LIFTARM 24.5' WING LEFT98-
8D0340	U-BOLT 3/4 X 4-1/16 X 7-3/4"SQ	8K1134	LIFTARM 28' WING WIDE 00-
8D2460	SAFETY CHAIN 20200# 3/8" X 4'	8K1134N	LIFTARM 32.5' WING & NRRW 07-
8D2470	SAFETY CHAIN 30400# 7/16" X 5'	8K1146	LIFTARM18.5-32.5 FRNTCNTR98-
8D3212	MALE TIP 3/4"-16 ORB ISO	8K1152	LIFTARM 16-32.5 REARCNT98-
8D8490	PIONEER/ISO TIP HLDR BNT 97-	8K1178	LIFTARM 38.5-47 RRC+WING 00-
8D8502	HYD HOSE HOLDER H-DUTY BLK 14-	8K1210	SHIM 3/4" FRNT-CNTR CYLATCH12-
8D8522	JACK 5000# TOP CRANK 15"LIFT	8K1212	A-FRAME 18.5-47 FRNTCNTR 98-
8D9108	ROLL PIN 1/4 X 2" ZINC	8K1221	A-FRAME18.5-32.5 REARCNT98-
8D9110	HAIRPIN CLIP LARGE (1"CYL PIN)	8K1224	A-FRAME 38.5-47 REARCNT98-
8D9466	HYD CYL 4.5 X 16" 3500PSI 99-	8K1232	A-FRAME 24.5' WING 98-
8G2284	NYLON TIE .187 X 7-1/2" YELLOW	8K1242	A-FRAME 28-47' WING 98-
8G2285	NYLON TIE .187 X 7-1/2" GREEN	8K1280	WING TRUSS FRONT 18.5 & 21.5'
8H2316	EXT MNT ARM 6"W/HRDWR M94-M108	8K1282	WINGTRUSS R18.5 F32.5 & F44.5
8J0910	STL 1-1/8 X 10"C-C LNK BLK 09-	8K1284	WING TRUSS REAR 21.5'
8J0920	LINK PT 1 TO 2 (1 STFNR) 09-	8K1290	STUB TUBE LEFT FRONT 18.5'
8J2230WL	GANG 3 BLADE22"8W-N - L	8K1292	STUB TUBE RGHT FRONT 18.5'
8J2230WR	GANG 3 BLADE22"8W-N - R	8K1300	STUB TUBE LEFT FRONT 21.5'
8J5100	#6 JIC(M) X #6 JIC(M) UNION	8K1302	STUB TUBE RGHT FRONT 21.5'
8J5200	#10 JIC(F) X #6 JIC(M)HEX BUSH	8K1304	STUB TUBE LEFT REAR 21.5'
8J5300	TEE #6 JIC (MALE) 3X	8K1306	STUB TUBE RGHT REAR 21.5'
8J5510	3/4"-16 ORB X #6 JIC(M) STR	8K1310	WING 24.5' LEFT 98-
8J5520	3/4"-16 ORB X #10 JIC(M) STR	8K1312	WING 24.5' RGHT 98-
8J5550	1-1/16" - 12ORB#10JIC(M)STR	8K1320	WING 28' & 32.5' LEFT
8J5620	3/4"-16 ORB X #6 JIC(F-SW)STR	8K1322	WING 28' & 32.5' RGHT
8J5682	3/4"-16ORB(2X)ADJUSTABLE UNION	8K1350	WING 38.5' & 44.5' LEFT
8J5690	3/4-16X3/4-16 ORB M-SW90*UNION	8K1352	WING 38.5' & 44.5' RGHT
8J5700	#6 JIC(F-SW) X #6 JIC(M)90*ADP	8K1355	WING EXT 32.5' (29") 07-
8J5710	#10 JIC(F-SW)X#10 JIC(M)90°ADP	8K1358	WING EXT 44.5' (40.1") 98-
8J5980	9/16"-18ORB M X 3/4"-16ORB F	8K1370	REST PRT 2 WING 47'DSK 09-
8J6000	9/16"-18 ORB X #6 JIC(M)90*ADP	8K1380	WING 47' PRT 1 LEFT 09-
8J6010	3/4"-16 ORB X #6 JIC(M)90*ADP	8K1382	WING 47' PRT 1 RGHT 09-
8J6020	3/4"-16 ORB X #10 JIC(M)90*ADP	8K1390	WING 47' PRT 2 LEFT 09-
8J6030	7/8"-14 ORB X #10 JIC(M)90°ADP	8K1392	WING 47' PRT 2 RGHT 09-
8J6060	3/4"-16ORB X #6JIC(F-SW)90*ADP	8K1532	CYLPULL 1/2X2.5- 12.25" DSK84-
8J7040	THERMAL RELIEF MANIFLD 4000PSI	8K1540	TUBE 2-1/4X1.27ID- 1/2" DSK84-
8J7216	#6JIC(M)X6JIC(F)1/16"RSTR BLKZ	8K1555	ADJ GANG LINK BAR
8K0050	MNT BRKT ADJ DPRSS MANFLD 12-	8K1560	ADJ GANG ADJ HOUSING
8K1010	HITCH DIAMOND DISK 84-	8K1565	SCRAPER ADJ GANG 3BLADE
8K1040	CENTER FRAME 14.5' LEFT 84-	8K1570	PIVOT RETAINER ADJ GANG
8K1042	CENTER FRAME 14.5' RGHT 84-	8K1575	ADJ GANG MNT TUBE
8K1050	CENTER FRAME 16' LEFT 84-	8K1580	REAR CAP ADJ GANG

Stock Code	Description	Stock Code	Description
8K1582	ANGLE GAGE ADJ GANG	8K4420	CLAMP FLAT 1/2 X 2- 4-1/4" 84-
8K1585	SWIVEL CRANK HANDLE	8K4420	CLAMP FLAT 1/2 X 2- 4-1/4" 84-
8K1610	PIN 3/4 X 6.25" TRNSPRTLCK 84-	8K4423	FILLER FLAT 5/8 X 2.5- 3" 08-
8K1620	PIN 1-1/4 X 6-1/8" 84-	8K4430	ARM 5/8X2.5- 15.375"HR1044PNTD
8K1640	PIN 1-1/2 X 10-5/8" HITCH 84-	8K4440	STL 5/8 PNTD GRN SCRAPRTUBE11-
8K1660	PIN 1-1/2 X 15-1/2" HARDEND84-	8K4449	BRCKT ADJ OFFSET SCRAPER 99-
8K1755	EYEBOLT 1.5"DIA X 1.26EYE YZ 12-	8K4620	SCRAPER MNT TUBE 2 SQ X 48"
8K1760	BOLT 1-1/4"-7NC X 3-7/8" PIVOT	8K4630	SCRAPER MNT TUBE 2 SQ X 58"
8K1770	SHAFT ANGLE ADJ SCREW	8K4635	SCRAPER MNT TUBE 2 SQX 62-1/2"
8K1775	SHAFT ANGLE ADJ SLIDE	8K4640	SCRAPER MNT TUBE 2 SQ X 68"
8K1900	SEAL GBGI V WALKNG TANDM 01-	8K4650	SCRAPER MNT TUBE 2 SQ X 78"
8K1920	RETAINING RING 2-7/8" INV 00-	8K4660	SCRAPER MNT TUBE 2 SQ X 88"
8K2650	GANG 5 BLADE LEFT RR/RGHT FRNT	8K4670	SCRAPER MNT TUBE 2 SQ X 98"
8K2652	GANG 5 BLADE RGHT RR/LEFT FRNT	8K4680	SCRAPER MNT TUBE 2 SQ X 108"
8K2660	GANG 6 BLADE LEFT REAR	8K4690	MNT TUBEASSY 2SQX 47" 3&1 HL
8K2660C	GANG 6 BLADE LFT REAR CNTR W/N	8K4692	MNT TUBEASSY 2SQX 47.5" 2&2 HL
8K2660S	GANG 6 BLADE RGT FRNT CNTR W/S	8K4698	MNT TUBEASSY 2SQX 67.5" 4&2 HL
8K2662	GANG 6 BLADE RGHT REAR	8K4700	MNT TUBEASSY 2SQX 67.5" 3&3 HL
8K2662C	GANG 6 BLADE RGT REAR CNTR W/S	8K4710	MNT TUBEASSY 2SQX 77.5" 4&3 HL
8K2662S	GANG 6 BLADE LFT FRNT CNTR W/S	8K4922S	BLADE DISK 1/4X22" 5BLT4"ID LC
8K2663	GANG 6 BLADE RGHT RR BRG2&3	8K4925	GUARD HUB CAP 517 06-
8K2664	GANG 6 BLADE LEFT RR BRG2&3	8K4930	SPACER 5/8" (7K2065) PNTD 06-
8K2670	GANG 7 BLADE LEFT RR/RGHT FRNT	8K4935	PLATE SNGLDSK(7K2075)PNTD 06-
8K2672	GANG 7 BLADE RGHT RR/LEFT FRNT	8K4945	BRCKT W/517HUB SNGLDSK RGHT06-
8K2673	GANG 7 BLADE RGHT FRNT BRG2&3	8K4950	22" SINGLE DISK ASSY RGHT 06-
8K2674	GANG 7 BLADE LEFT FRNT BRG2&3	8K5505	U-BOLT 3/4 X 2-1/8 X 4-1/4" SQ
8K2680	GANG 8 BLADE LEFT RR/RGHT FRNT	8K5515	U-BOLT 3/4 X 4-1/16 X 6" SQ
8K2680S	GANG 8 BLADE RGT FRNT CNTR W/S	8K5520	U-BOLT 3/4 X 6-1/8 X 7-1/2" SQ
8K2682	GANG 8 BLADE RGHT RR/LEFT FRNT	8K6313	HYD CYL 2.25X6" 1.25"RD 11-
8K2682S	GANG 8 BLADE LFT FRNT CNTR W/S	8K6845	BOX 6BLD REAR GNG PKG DSK 17-
8K2690	GANG 9 BLADE LEFT RR/RGHT FRNT	8K7033	11L X 15 LRF ON 15X8X6 WHEEL
8K2690C	GANG 9 BLADE LFT REAR CNTR W/N	8K7042	12.5L X 15 LRF ON 15X10X8 WHL
8K2690S	GANG 9 BLADE RGT FRNT CNTR W/S	8K7430	340/65R18 ON 18X11X8 WHL-1.5OF
8K2692	GANG 9 BLADE RGHT RR/LEFT FRNT	8K8000	STL 7K2045 3/8X3.5 PNTDLGHT09-
8K2692C	GANG 9 BLADE RGT REAR CNTR W/S	8K8010	TUBE LGHT BRCKT 1.5SQ PNTD 00-
8K2692S	GANG 9 BLADE LFT FRNT CNTR W/S	8K8020	STL 12GA MNTNG BRCKT LIGHT 00-
8K2700	GANG 10 BLADE LFT RR/RGHT FRNT	8K8030A	MODULE AG ENHNCDW/BRAKE6PIN08-
8K2700C	GANG 10 BLADE LFT REARCNTR W/N	8K8070B	MAIN HRNSS 7PN 32' W/BRAKE 09-
8K2702	GANG 10 BLADE RGHT RR/LFT FRNT	8K8075A	EXT HARNESS 18' DEUTSCH 07-
8K2702C	GANG 10 BLADE RGT REARCNTR W/S	8K8077	EXT HARNESS 24' DEUTSCH 16-
8K2706	GANG 10 BLADE 18.5LFT REARCNTR	8K8090B	LIGHT LED AMBER 2WR DTSCH 12-
8K2708	GANG 10 BLADE 18.5RGT REARCNTR	8K8095B	LIGHT LED RED 3WIRE DTSCH 12-
8K2720	GANG 12 BLADE RGHT FRONT 09-	8K8105A	EXT HARNESS 26' 2WIRE DTSCH 07-
8K2722	GANG 12 BLADE LEFT FRONT 09-	8K8210	BRCKT W/SCKT SMV ATCH4-8"98-
8K3002	WRENCH GANG 3-1/8" HEX BLCK00-	8K9106	PIN 1-1/4 X 4-3/8" HRDND 1/4HL
8K4200	CLAMP GNGMNT W/PEG CAST PNTD	8K9174	STROKE CNTRL 1/2" 2"ROD 96-
8K4200	CLAMP GNGMNT W/PEG CAST PNTD	8K9176	STROKE CNTRL 3/4" 2"ROD 96-
8K4210	CLAMP GANG MNT CAST PNTD	8K9178	STROKE CNTRL 1" 2"ROD 96-
8K4300	CLAMP SCRAPER MNT CAST PNTD	8K9180	STROKE CNTRL 1-1/4" 2"RD 96-
8K4410	SCRAPER DMND/2510DT 3/16" PNTD	8K9250	900#WGHT PKG W/HRDWR DSK/CLTR
8K4415	SCRAPER DIAMND IN 5/16" 07-	8K9640	HYD CYL 4 X 36" W/3" STOP TUBE
8K4417	SCRAPER DIAMND OUT 5/16" 07-	8K9650	HYD CYL 5 X 36" W/3" STOP TUBE

Stock Code	Description	Stock Code	Description
8L0258	U-BOLT 5/16 X 1-1/2 X 2-1/2"SQ	8X0112	BOLT 3/4-10NC X 2-1/4" GR5 YZ
8N0250	HYD PRESSURE GAGE 2.5"	8X0113	BOLT 3/4-10NC X 5" GR5 YZ
8N3018	3/8X 18"HYD HOSE #6FJX3000PSI	8X0114	BOLT 3/4-10NC X 3" GR5 YZ
8N3028	3/8X 28"HYD HOSE #6FJX3000PSI	8X0115	BOLT 3/4-10NC X 3-1/2" GR5 YZ
8N3035	3/8X 35"HYD HOSE #6FJX3000PSI	8X0120	BOLT 3/4-10NC X 9" GR5 YZ
8N3048	3/8X 48"HYD HOSE #6FJX3000PSI	8X0121	BOLT 3/4-10NC X 6-1/2" GR5 YZ
8N3060	3/8X 60"HYD HOSE #6FJX3000PSI	8X0123	BOLT 3/4-10NC X 5-1/2" GR5 YZ
8N3070	3/8X 70"HYD HOSE #6FJX3000PSI	8X0125	BOLT 3/4-10NC X 10" GR5 YZ
8N3084	3/8X 84"HYD HOSE #6FJX3000PSI	8X0134	BOLT 7/8-9NC X 4" GR5 YZ
8N3124	3/8X 124"HYD HOSE #6FJX3000PSI	8X0138	BOLT 1-8NC X 5-1/2" GR5 YZ
8N3136	3/8X 136"HYD HOSE #6FJX3000PSI	8X0146	BOLT 1-8NC X 8-1/2" GR5 YZ
8N3150	3/8X 150"HYD HOSE #6FJX3000PSI	8X0152	BOLT 1-1/4-7NC X 3.75 FULLTHD
8N3160	3/8X 160"HYD HOSE #6FJX3000PSI	8X0170	SCREW 8 X .75" FLANGE HD
8N3180	3/8X 180"HYD HOSE #6FJX3000PSI	8X0202	NUT 3/8"-16NC NY-LOCK GR2 YZ
8N3204	3/8X 204"HYD HOSE #6FJX3000PSI	8X0203	NUT 3/8"-16NC SERFLANG GR2 YZ
8N3228	3/8X 228"HYD HOSE #6FJX3000PSI	8X0208	NUT 8-32 HEX YZ SER FLNG
8N3288	3/8X 288"HYD HOSE #6FJX3000PSI	8X0211	NUT 5/16"-18NC SERFLANG GR2 YZ
8N3312	3/8X 312"HYD HOSE #6FJX3000PSI	8X0223	NUT 1/4"-20NC SERFLANG GR2 YZ
8N3330	3/8X 330"HYD HOSE #6FJX3000PSI	8X0234	NUT 7/16"-14NC NY-LOCK GR2 YZ
8N3348	3/8X 348"HYD HOSE #6FJX3000PSI	8X0242	NUT 1/2"-13NC NY-LOCK GR2 YZ
8N3360	3/8X 360"HYD HOSE #6FJX3000PSI	8X0246	NUT 1/2"-13NC SERFLANG GR2 YZ
8N4138	1/2X 138"HYD HOSE#10FJX3000PSI	8X0250	NUT 5/8"-11NC HEX GR2 YZ
8N4198	1/2X 198"HYD HOSE#10FJX3000PSI	8X0260	NUT 3/4"-10NC HEX GR2 YZ
8N4228	1/2X 228"HYD HOSE#10FJX3000PSI	8X0261	NUT 3/4"-10NC NY-LOCK GR2 YZ
8N4546	1/2X 546"HYD HOSE#10FJX3000PSI	8X0265	NUT 3/4"-10NC CNTRLOCK GR2 YZ
8N4624	1/2X 624"HYD HOSE#10FJX3000PSI	8X0266	NUT 3/4"-10NC SERFLANG GR2 YZ
8N7000	ADJ DOWN PRESSURE MANIFLD 12-	8X0270	NUT 7/8"-9NC CNTRLOCK GR2 YZ
8S1120	SIGN SLOW MOVING VEHICLE(SMV)	8X0280	NUT 1"-8NC HEX GR2 YZ
8S1126	MNT SPADE W/HRDWR SMV SIGN	8X0281	NUT 1"-8NC NY-LOCK GR 2 YZ
8S2990	HYD HOSE CLAMP-LARGE-NYLON	8X0283	NUT 1-1/4"-7NC JAM GR2 YZ
8S3095	CAPLUG FITS ISO HYD COUPLR 08-	8X0285	NUT 1-1/2"-6NC HEX GR2 YZ
8T1040	HYD CYL 4.0 X 10" REPHASE 96-	8X0285A	NUT 1-1/2"-6NC NY-LOCK GR 8 YZ
8T1045	HYD CYL 4.5 X 10" REPHASE 96-	8X0286	NUT 1-1/2"-6NC JAM GR2 YZ
8T1050	HYD CYL 5 X 10" REPHASE 96-	8X0288	NUT 1-1/4"-7NC NY-LOCK GR8 YZ
8T1055	HYD CYL 5.5 X 10" REPHASE 96-	8X0300	LOCKWASHER 5/16" YLW ZNC
8T1060	HYD CYL 6 X10 W/STRK CNTRL 96-	8X0304	LOCKWASHER 5/8" YLW ZNC
8T2514	SPACER WNGFLT2.25ODX9/16" 99-	8X0306	LOCKWASHER 3/4" YLW ZNC
8T3606	PIN 1.5 X 5.38" GREASABL 99-	8X0307	LOCKWASHER 7/8" YLW ZNC
8T3620	PIN 1-1/2 X 12-1/2" HRDND&ZINC	8X0309	LOCKWASHER 1" YLW ZNC
8T4132	WLKNG TNDM 7.5"C-C 2" ID 98-	8X0315	LOCKWASHER 1-1/2" YLW ZNC
8T4350	TRNS LCK W/UHMW10.5"(2.4RD)96-	8X0317	WASHER 3/4" SAE FLAT YZ
8T4380	HOLDER CYL LOCK 4"&6" MNT 96-	8X0318	WASHER 3/4"(13/16"ID)FLAT YZ
8T4385	HOLDER MANUAL-PAK 3/4/6MNT09-	8X0327	WASHER 1-1/4" SAE FLAT YZ
8W1357	HEX HEAD PLUG 9/16"-18 ORB	8X0352	WASHER 1-1/2 X 3.50" OD YZ
8X0000	BOLT 1/4-20X3/4" FLLTHD GR5 YZ	8X0355	WASHER 1-1/2"IDX2.25"X10GA PLN
8X0021	BOLT 5/16-18NC X 3/4"GR5 YZ	8X0368	WASHER 1-1/2" SAE FLAT PLN
8X0044	BOLT 7/16-14NC X 3-1/2"GR5 YZ	8X0402	HAIRPIN CLIP 1/8 X 2-9/16"
8X0063	BOLT 1/2-13NC X 1-1/2" GR5 YZ	8X0405	SNAPPER PIN 1/4 X 1.75"
8X0067	BOLT 1/2-13NC X 2-1/4" GR5 YZ	8X0418	COTTER PIN 5/16 X 2-1/2" YZ
8X0072	BOLT 1/2-13NC X 3-3/4" GR5 YZ	8X0440	CLEVIS PIN 5/8 X 3-7/8" YZ
8X0074	BOLT 1/2-13NC X 4-1/2" GR5 YZ	8X0523	ROLL PIN 5/16 X 2-1/2" PLN
8X0110	BOLT 3/4-10NC X 1-1/4" GR5 YZ	8X0750	PIN XEDNI16P8 BOSTR3/220MA RED

Stock Code	Description	Stock Code	Description
8X0803	STL .25 MODULE BRACKET 16-		
8X1115	CRG 3/8-16NC X 1-1/2" GR2 ZN		
8X1120	CRG 3/8-16NC X 2" GR2 ZN		
8X1130	CRG 3/8-16NC X 3" GR2 ZN		
8X1140	CRG 3/8-16NC X 4" GR2 ZN		
8Y1900	KIT DECAL DK2610 18'STD DISK 1		
8Y1905	KIT DECAL DK2610 21'STD DISK 1		
8Y1910	KIT DECAL DK2610 STD DISK 14-		
8Z0055	PLATE SERIAL NUMBER UNIVRSL		
8Z0475	DECAL ADJ GANG ANGLE GAGE		
8Z0800	REFLECTOR AMBER ADHSVBCK98-		
8Z0805	REFLCTR REDORANGE ADHSVBK99-		
8Z0810	REFLECTOR RED ADHSV-BACK 98-		
8Z1000	MANUAL-PAK 3DIA X 11.75" 09-		
8Z1090	OPER MAN DMND DSK & 2510DT 00-		

History of Summers Manufacturing Co., Inc.

- 1965 – Summers Manufacturing is founded by Harley Summers, who purchases patent rights for Goebel truck and pickup hoists from the Goebel Brothers of Lehr, ND. These hoists, produced in Harley Summers' blacksmith shop the first year, were distributed nationwide by a Cincinnati, Ohio, dealer. With increasing sales, the company soon outgrows the small shop. Summers wins the Herman harrow contract, beginning the company's Herman culti-harrow line. Summers builds a 7,200 square-foot factory in Maddock to meet the demand for truck and pickup hoists, as well as Herman harrows.
- 1969 – Firm incorporates and becomes officially known as Summers Manufacturing Company, Inc.
- 1970 – Summers purchases rights to manufacture/market the Herman Harrow.
- 1973 – Company builds new 20,000 square-foot plant and offices in Maddock, adding a 20,000 square-foot assembly plant in the fall of 1975 (completed in January 1976), bringing total square footage of Maddock factories to 47,000.
- 1977 – Summers introduces the Agri-sprayer, used in conjunction with the Herman culti-harrow to incorporate herbicides and liquid fertilizer.
- 1980 – Company purchases manufacturing and distributing rights to Crown rockpickers from Crown Manufacturers of Regina, Saskatchewan. This forces another expansion project – a 26,000 square foot factory on a 24 acre site in Devils Lake, ND Industrial Park.
- 1981 – Company establishes a branch facility in Regina, Saskatchewan.
- 1982 – Devils Lake plant begins operations in January, manufacturing supersprayers and rockpickers. The Maddock factory begins producing the Superweeder, a combination cultivator and harrow.
- 1983 – Summers buys manufacturing and distributing rights to the Fargo Field Sprayer line from Mid America Steel (formerly Fargo Foundry), Fargo. This field sprayer line is manufactured at the Devils Lake plant. Harley Summers is selected North Dakota's small-businessman of the year by the Small Business Administration.
- 1984 – Herman Diamond Disk, a disk harrow made in a diamond shape to reduce blade breakage from rocks, comes off the assembly line.
- 1985 – Summers signs a contract with Melroe Company of Bismarck to obtain exclusive manufacturing rights to the Melroe harrow line.
- 1989 – Summers purchases TorMaster Company of Hordean, Manitoba, giving the company a line of rolling packer equipment, comprised of harrow packers and hydraulic fold coil packers.
- 1992 – A new engineering office/parts department is added to the Devils Lake factory.
- 1993 – Company adds two new products: a pickup-mounted sprayer with booms of 80 and 90 feet, and the Summers Superharrow, an extra-heavy-duty residue-management tool designed for the minimum and no-till farmer.
- 1994 – a 50 by 125 foot addition to the Maddock factory is completed. Construction begins on a 24,576 square-foot addition to the Devils Lake factory, which enables the company to increase production of truck-mounted and pull-type supersprayers and rockpickers.
- 1996 – 1500 square foot office area added to the Maddock plant. Company introduces Chisel Plow with floating hitch and 700# trip assembly.
- 1997 – 16,800 square foot warehouse in Maddock purchased from local business.
- 1999 – Company introduces the Ultimate suspended boom trailer sprayer with hydraulic folding booms. Additional sizes added to the Chisel Plow line, now ranging from 28' to 54'.
- 2000 - Company introduces the Supercoulter, the innovative solution for excessive field residue management on no-till, minimum-till, and conventional-till farming operations.
- 2001 - Cold storage building completed at Devils Lake. Company extends boom lengths up to 110 feet on the Ultimate Supersprayer.
- 2002 - Company adds a warehouse and service man in Aberdeen, SD.
- 2003 - Company introduces the Ultimate NT Supersprayer featuring a bolt on axle for easier adjustment, and a new family of tanks that feature a drainable sump and a common width dimension.
- 2004 - A 124 ft. x 310 ft. addition is added onto the current Devils Lake plant.
- 2005 - The Summers Superroller is added to the "Field Tested Tough" product line. Additional sizes of 56', 58' and 60' are added to the Superchisel line. Ultimate-Ultra NT Supersprayer introduced featuring 120' & 133' booms.
- 2006 - The Summers Coulter-Chisel, Rolling Choppers and 30' Superroller were included in product line.
- 2007 - 62' & 84' 5 Section Landrollers and a 20' Coulter-Chisel were introduced.
- 2008 - Disk-Chisels, ranging from 16' to 40' widths, are added to product line.
- 2009 – M105 and M108 Mounted Harrows added to selection of Mounted Attachments. SuperHarrow 2650, 50' SuperCoulter, Hydraulic Fold Rolling Chopper and 36" diameter Landrollers introduced.
- 2010 – Rolling Basket and 47' Diamond Disk added to product line. A 124 ft. x 310 ft. addition to Devils Lake factory built for a state of the art paint system.
- 2011 – Additional Supercoulter sizes were added along with larger tires for tillage implements. Ultimate and Ultra Supersprayers received an additional tank size of 1650 gallons. Front Caster Wheel option was made available for chisel implements.
- 2012 – 41', 46' & 53' Trail Type Landroller added to product line. Additional Superchisel sizes of 16' & 20' were added.
- 2013 – DT9530 added to product line. Internal Scraper in Rolling Baskets introduced. Finishing Coulter Gang becomes standard on the Diamond Disk and 2510 DT. Corporate offices opened at Devils Lake plant. New building and location for the Aberdeen warehouse.
- 2014 – Introduced the VRT2530 (Variable Rate Tillage).
- 2015 – Introduced the VT Flex Applicator and Spray Fill Xpress.

Summers distributes on a wholesale level to dealers and distributors throughout markets in North Dakota, South Dakota, Minnesota, Montana, Iowa, Washington, Idaho, Oregon, Utah, Colorado, Kansas, Nebraska, Oklahoma, Texas, Manitoba, Saskatchewan, Alberta, British Columbia, Kazakhstan, Russia and Australia, making it an international company.

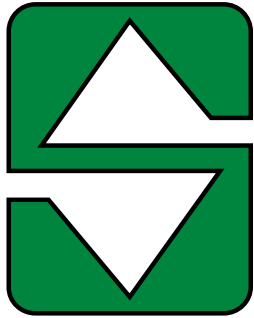

SUMMERS[®]

... Field Tested TOUGH!



Tillage



Rock Picker



Land Rollers/Packers



Cultivators/Harrows



Mounted Attachments



Sprayers



1-800-732-4347 • www.summersmfg.com